

SMARTBANK PRO

SmartBank PRO is the most advanced stand-alone split charging device available. Utilising industry-accepted "best method" split charging, SmartBank PRO introduces no voltage drop, does not force feed batteries, and allows capacity sharing between battery banks to stretch battery run-times to the max.

On board DSP (Digital Signal Processing) prevents the SmartBank PRO being confused by transient loads and built in data-logging allows you to track system performance and tune it to maximise charge efficiency.

SmartBank PRO can be batch programmed by PC which is ideal for fitting across large fleets. The optional PC Interface kits include free software, serial: USB converter, adaptor cable and allows:

- programming of advanced features & alarms,
- data logging,
- real-time monitoring,
- and system diagnosis.

SmartBank PRO and its subsequent components are available for large volume OEM customers. Also available are custom looms, pre-programming, and your own specification of plugs/ sockets for integration into existing wiring looms.

- **Advanced split charging** for larger systems & professional users.
- **Built-in data logging** alongside manual and computer adjustment of split charge settings.
- **Charge prioritising & capacity sharing** allows you to prioritise charge order and share spare engine battery capacity with auxiliaries.
- **Fully programmable** with eight programmable inputs & outputs to allow easy integration of alarms, interlocks, and automatic reset of flat battery protection systems etc.
- **Suitable for 2 or 3 battery banks** Allowing you to apply your device to a range of different applications

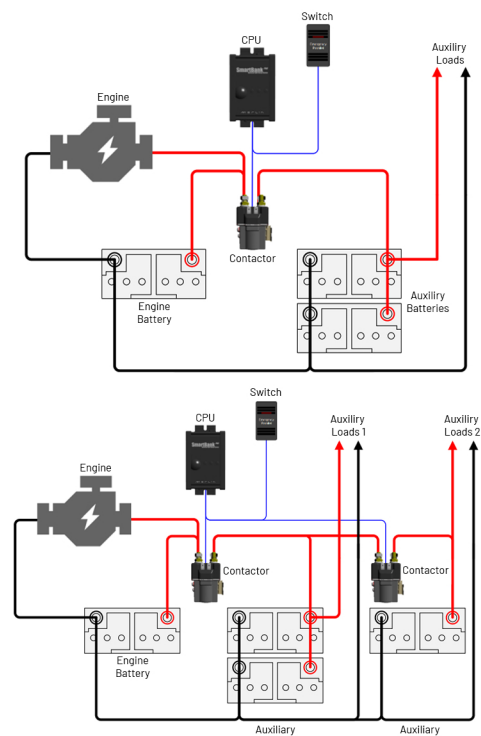

PART # (STANDARD PRDDUCT)	04-8011	04-8012	04-8013	04-8014
NUMBER OF BATTERY BANKS	2	3	2	3
CONTACTOR CURRENT (CONTINUOUS)	200A	200A	200A	200A
CONTACTOR CURRENT (5 MINS)	250A	250A	250A	250A
CONTACTOR CURRENT (CRANKING)	725A	725A	725A	725A
POWER CONSUMPTION	<10MA	<10MA	<5MA	<5MA
CONNECT/DISCONNECT VOLTAGE	FULLY ADJUSTABLE	FULLY ADJUSTABLE	FULLY ADJUSTABLE	FULLY ADJUSTABLE
ADJUSTMENT RANGE				
TIME ADJUSTMENT RANGE	FULLY ADJUSTABLE	FULLY ADJUSTABLE	FULLY ADJUSTABLE	FULLY ADJUSTABLE
CPU WEIGHT EX CABLES (G)	178	178	178	178
CPU DIMENSIONS EX CABLES (MM)	68 X 110 X 32	68 X 110 X 32	68 X 110 X 32	68 X 110 X 32
CONTACTOR WEIGHT (G)	375	375	375	375
CONTACTOR DIMENSIONS (MM)	91 X 50 X 39	91 X 50 X 39	91 X 50 X 39	91 X 50 X 39
COMPLIANCE		EMC2002/95/EC, CE, ISO7637-2, SAE J1171		
E-MARK CERTIFICATION	YES	YES	YES	YES

All specifications are provided in best possible faith but may be subject to change without notice. All business is transacted according to our Standard Terms & Conditions, a copy of which is available upon request.