

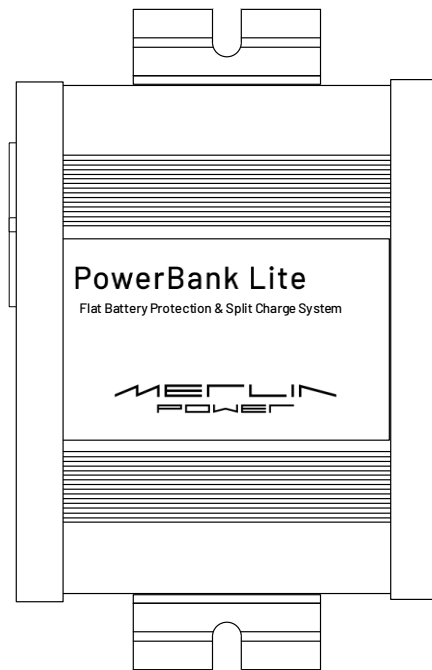

POWERBANK LITE

USER & INSTALLATION GUIDE

Revision: A



Merlin Equipment Ltd
Clyst Court
Hill Barton Industrial Estate
Exeter, Devon, EX5 1SA
United Kingdom
T: +44 (0)1202 697979

Merlin Power Systems
332-4 West Montauk Highway
Hampton Bays
New York NY11946
United States of America
T: +1(631)594 5102

www.merlinequipment.com

WARNING

Your attention is drawn to "Caution!" and "Warning!" statements throughout this manual.

"Caution!" refers to practices that may cause damage to the Merlin Product or your electrical system.

"Warning!" identifies practices that may cause injury or death.

PowerBank Lite is designed for installation by qualified and competent electrical engineers.

Qualified and competent engineers will be familiar with safe working practices, local health & safety legislation and the proper and safe use of tools and equipment.

Therefore not all obvious practices that may lead to system damage, injury or death are detailed within this manual.

If you are in anyway unsure about any aspect of the installation or use of PowerBank Lite, contact your Dealer or Merlin Power Systems for advice.

PRECAUTIONS

- This product is designed for use in 12 and 24 Volt DC vehicular systems depending on model. Use in other than its designed application may result in fire, electric shock or other injury.
- DO NOT disassemble, modify or alter. Doing so may result in an accident, fire or electric shock.
- USE ONLY in vehicles with a NEGATIVE GROUND. Failure to do so may result in fire, electric shock, damage or other injury.
- FUSES: Use the correct ampere rating when replacing fuses. Failure to do so may result in fire, injury, electric shock or damage.
- DO NOT install or operate the CPU in an explosive atmosphere.
- DO NOT install or expose the CPU to excessive temperatures or humidity.
- If in any doubt consult a suitably qualified and competent engineer or the supplier.
- DO NOT substitute Contactors or switches with any other types that have not been approved and tested.
- MAINTENANCE. If you have problems or suspect device failures DO NOT attempt to repair the unit yourself. Return it to your Dealer or Merlin for servicing.

APPROVALS AND CONFORMITY

CERTIFICATE OF CONFORMITY



Declaration of Conformity

Merlin Equipment Limited, hereby declares that the product marketed as PowerBank Lite is in compliance with the requirements of EU Electromagnetic Compatibility (EMC) Directive 2014/30/EU.

VCA Approval Number 10R06/02 12020 00

 10R06/02 12020 00

Test Report No: TS-220923357E/1



PowerBank Lite complies with RoHS (Reduction of Hazardous Substances) Directive 2011/65/EC. At the end of life, PowerBank Lite should be disposed of as normal electrical waste.

PowerBank Lite has been tested to and surpasses ISO-7637-2 for use Vehicles.

Signed:

A handwritten signature in blue ink, appearing to read 'James Hortop'.

James Hortop
Managing Director
Merlin Equipment Limited

INTRODUCTION

Thank you for choosing Merlin PowerBank Lite!

PowerBank Lite is a complete power management system designed to facilitate both split charging and flat battery protection on two battery banks.

PowerBank Lite is a remote battery switching system. This allows you to mount battery master switches in convenient locations such as dashboards or helm panels without needing to run heavy duty cables throughout the vehicle/boat.

PowerBank Lite is a flat battery protection system (PowerGuard). Using sophisticated battery monitoring techniques, PowerBank Lite detects when batteries start to run low. When the batteries have run below a certain level for a pre-set period of time, the battery will be disconnected. Note: on the primary battery circuit, this is inhibited from happening when the engine ignition is switched on.

PowerBank Lite is also a highly advanced split charging system (SmartBank) designed to allow charging of two battery banks.

PowerBank Lite will also operate on certain hybrid and electric vehicles and those fitted with both standard lead/acid, AGM, Gel and Lithium-Ion Batteries.

Please take the time to read and understand this manual before installation and use.

CONTENTS

WARNING	2
PRECAUTIONS	3
APPROVALS AND CONFORMITY	4
CERTIFICATE OF CONFORMITY	4
INTRODUCTION	5
CONTENTS	6
IDENTIFICATION OF SYSTEM COMPONENTS	7
INSTALLATION	9
POSITIONING OF PARTS	9
FIRST FIX INSTALLATION	9
ECU INSTALLATION	10
WIRING SCHEMATICS	11
NOTES	13
PROGRAMMING	14
POWERBANK LITE OPERATION	16
AFTER INSTALLATION	17
PRODUCT SPECIFICATIONS	17
PRODUCT ACCESSORIES	17
WARRANTY	18

IDENTIFICATION OF SYSTEM COMPONENTS

PowerBank Lite comprises a number of components. PowerBank Lite is configured for 2 battery bank installations, at 12 or 24 Volt DC. A number of additional components (e.g. Contactors, Switches) may also be used in the system.

PowerBank Lite Control Unit (ECU):

Contains main CPU and battery monitoring circuitry.



PowerBank Lite ECU

Contactors:

External contactors are used for both battery isolation (PowerGuard) and split charge between battery banks (SmartBank).



Contactor

Standard contactors are rated at 200A continuous for both 12 & 24V systems.

Control Switches:

Illuminated rocker switches can be provided for the switched inputs into the PowerBank Lite ECU. These can be used to control the isolation contactors and to provide emergency connection of the split charge contactor.

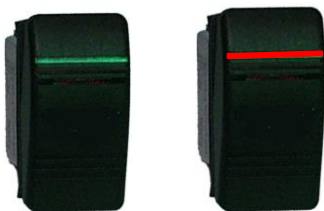

Attention: The Preview is based on a sample product; this can differ from the actual configuration supplied

Control Switches

PowerBank Lite control status can be communicated to the user via the LEDs contained within the switch. Alternatively, external LEDs can be provided.

Up to 4 Switches can be installed per vehicle as follows:

Switch 1 - Toggle Engine Battery (1) Switch

Switch 2 - Toggle Auxiliary Battery (2) Switch

Switch 3 - Flat Battery Protection Reset Switch (PowerGuard)

Switch 4 - Emergency Battery Parallel

System Cabling:

PowerBank Lite will be supplied with two mating wiring looms for connecting to external components.



Caution! Please ensure familiarity with the wiring of cable connectors, switches etc. It is highly recommended only personnel that have undertaken correct training attempt these tasks.

Warning! Incorrectly connected cables may damage PowerBank Lite or vehicle electrics and will invalidate the Warranty.

INSTALLATION

Warning! Isolate power supply before starting installation.

POSITIONING OF PARTS

PowerBank Lite main components (ECU & Contactors) do not need to be easily accessible from a user's perspective. Only the control switches need to be readily accessible to the user.

The following should be observed as parts of the PowerBank Lite are designed for wet/dirty environments, but others are not.

PowerBank Lite ECU:

The ECU is designed for location in a dry / clean environment. The ECU is **NOT** suitable for installation or operation in atmospheres where there is a risk of ignition or explosion. The ECU is **NOT** suitable for installation outside, under bonnet or in wet / damp cupboards.

Caution! Damage will occur if the ECU is allowed to get wet.

Warning! Do not install the ECU in a petrol/gas engine room environment.

Contactors:

The external isolation and split charge contactors are designed to be installed under hood, in wet engine room environments and battery compartments. The contactor is IP66 rated and will withstand hose downs. The contactor should be located as close as possible to the engine battery.

The contactors should be located as close as possible to the associated battery.

Control Switches:

The Switches are designed for location in a dry environment. They should be mounted on the dashboard or within easy view/access for the vehicle operator.

FIRST FIX INSTALLATION

Pre-Installation Preparation:

- Disconnect the main positive and negative from each battery bank to ensure no power is on the vehicle (up to 2 battery banks)
- Remove items (e.g. seats, access panels etc) to ensure easy installation
- Survey the sites where you wish to locate components.

Mount Components:

Mount the components in the agreed locations with the specifying Engineer. We recommend installing directly to bulkheads using stainless steel bolts. All nuts should be either of the Nyloc type or protected with a shake proof washer. Appropriately sized washers should be used to mount components to distribute component weight and loadings.

Plan and lay in cables:

Lay in the cables / wiring to the various components as per the system diagram supplied by the specifying / design Engineer. Ensure all cables are routed away from vehicle control devices and are suitably fixed and secured. Cables and wiring should not be installed above vehicle access points.

ECU INSTALLATION

The PowerBank Lite ECU is supplied with 2 Mounting Flanges. Each flange has a mounting slot to enable fitment of M5 bolts. Ensure that the unit is securely mounted to the vehicle using suitable bolts, washers and nuts. Unit dimensions are as detailed below:

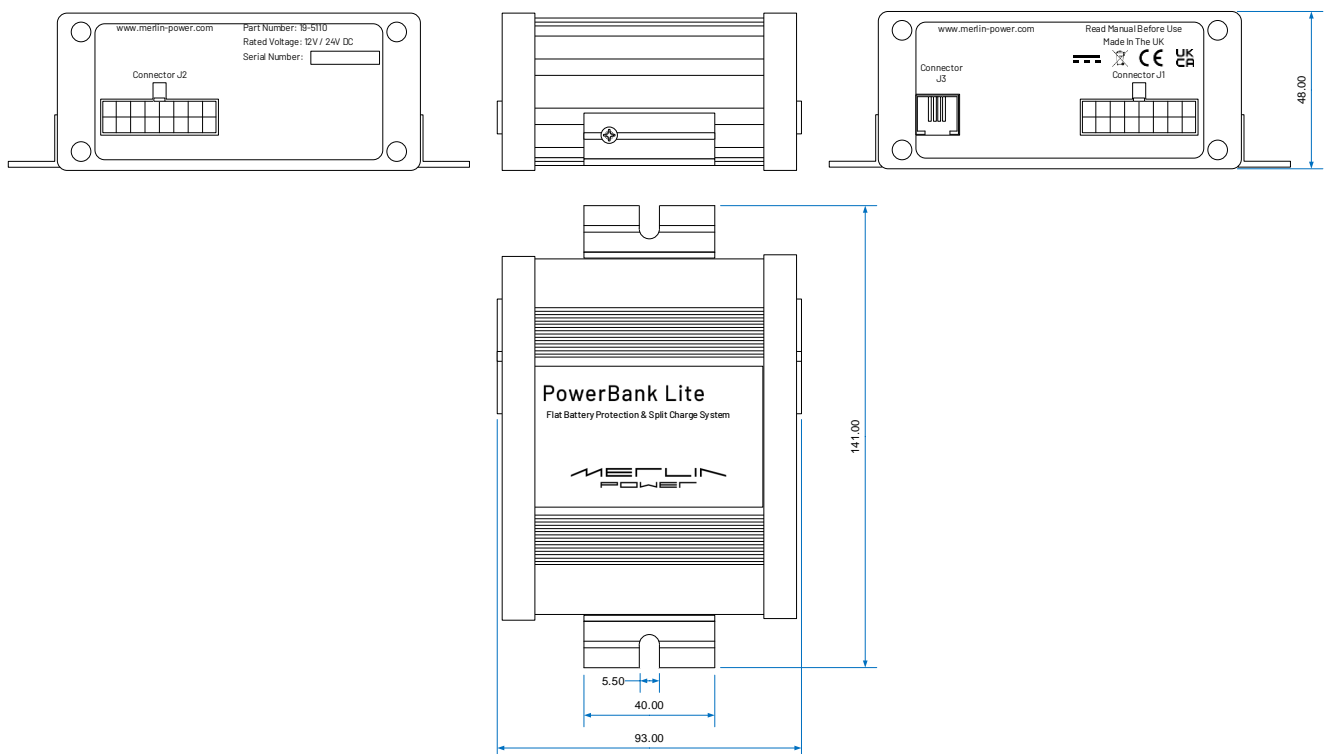

The PowerBank Lite wiring connections are as detailed within the Interface Control Document.

WIRING SCHEMATICS

TYPICAL SYSTEM LAYOUT:

This section is for information only. Please check with the specifying / design engineer. However, these diagrams show a typical layout which will give you an understanding of how the systems install and the component parts required.

The following 2 Battery Bank Example is based upon a typical installation:

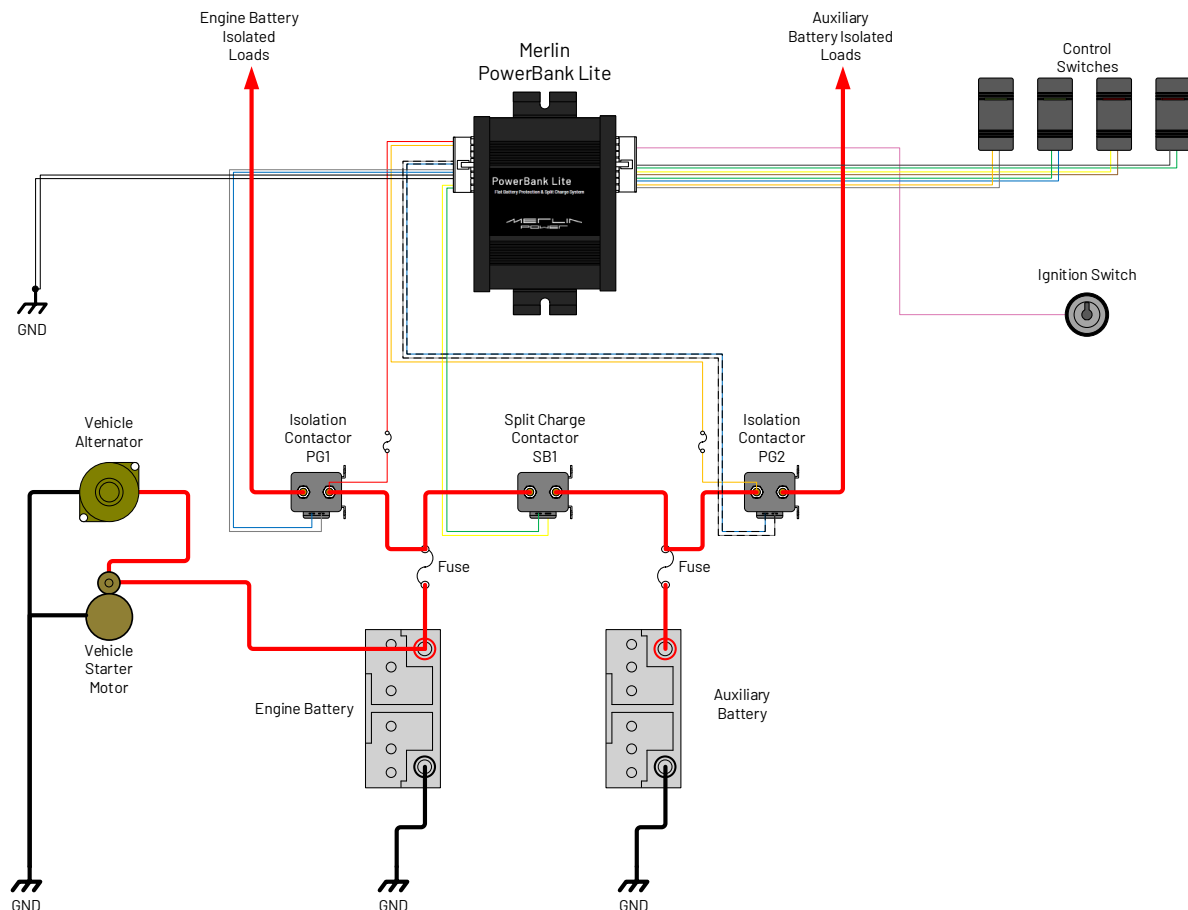

- **Caution!** Ensure always that the correct polarity is observed on the PowerBank Lite wiring. Serious damage to the PowerBank Lite ECU will occur if wires are shorted or connected the wrong way around.
- **Caution & Warning!** We recommend that appropriately rated fuses or circuit breakers are inserted between batteries and PowerBank Contactors to protect against short circuits. These should be rated based upon maximum vehicle alternator output (Amps) or a maximum current rating of 200A.
- **Caution & Warning!** Failure to connect the ignition inhibit wire may cause damage to the engine alternator and all electronics on the vehicle. Furthermore, critical loads like electric power steering may cease to operate.
- Fuses should be located as close as possible to the battery positive terminal of each battery bank
- High current cables must have a current rating higher than that of the associated fuse.

CONTROL & SENSE CABLING:

Part No: 19-5100 & 19-5101

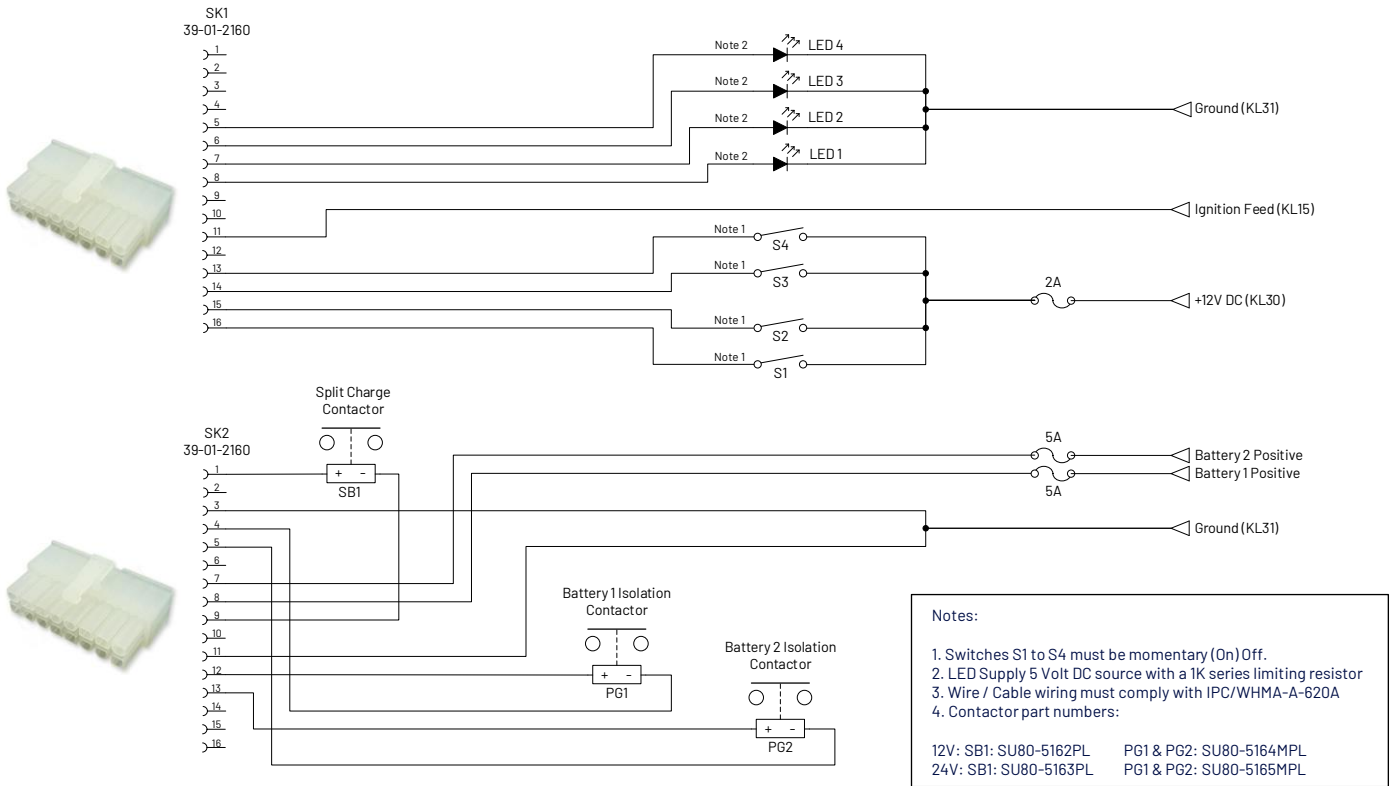

ECU Function	Cable Ident	Cable Wire Size	Cable Colour	J1 Connector
Not Required	56	0.75mm	Blue	3
Not Required	55	0.75mm	White	4
LED 4 Output	54	0.75mm	Grey	5
LED 3 Output	53	0.75mm	Yellow	6
LED 2 Output	52	0.75mm	Green	7
LED 1 Output	51	0.75mm	Orange	8
Switch 6 Input	36	0.75mm	Pink	11
Not Required	35	0.75mm	Orange	12
Switch 4 Input	34	0.75mm	Green	13
Switch 3 Input	33	0.75mm	Brown	14
Switch 2 Input	32	0.75mm	Blue	15
Switch 1 Input	31	0.75mm	White	16

ECU Function	Cable Ident	Cable Wire Size	Cable Colour	J2 Connector
Split Charge Contactor Positive	40	0.75mm	Yellow	1
Ground	0	0.75mm	Black	3
B1 Battery Isolator Negative	66	0.75mm	White	4
B2 Battery Isolator Negative	64	0.75mm	White / Black	5
Battery 2 Positive Sense	22	0.75mm	Orange	7
Battery 1 Positive Sense	21	0.75mm	Red	8
Split Charge Contactor Switch (Negative)	41	0.75mm	Green	9
Ground	0	0.75mm	Black	11
B1 Battery Isolator Positive	65	0.75mm	Blue	12
B2 Battery Isolator Positive	63	0.75mm	Blue / Black	13

Caution & Warning: PowerBank Lite switch supply wiring requires protection with a small inline fuse. This should be rated at 2A DC and used in every installation.

SWITCH CONNECTIONS:

The PowerBank Lite is supplied with four momentary rocker switches. Two with red LEDs and two with green LEDs. The switches should be connected as follows:

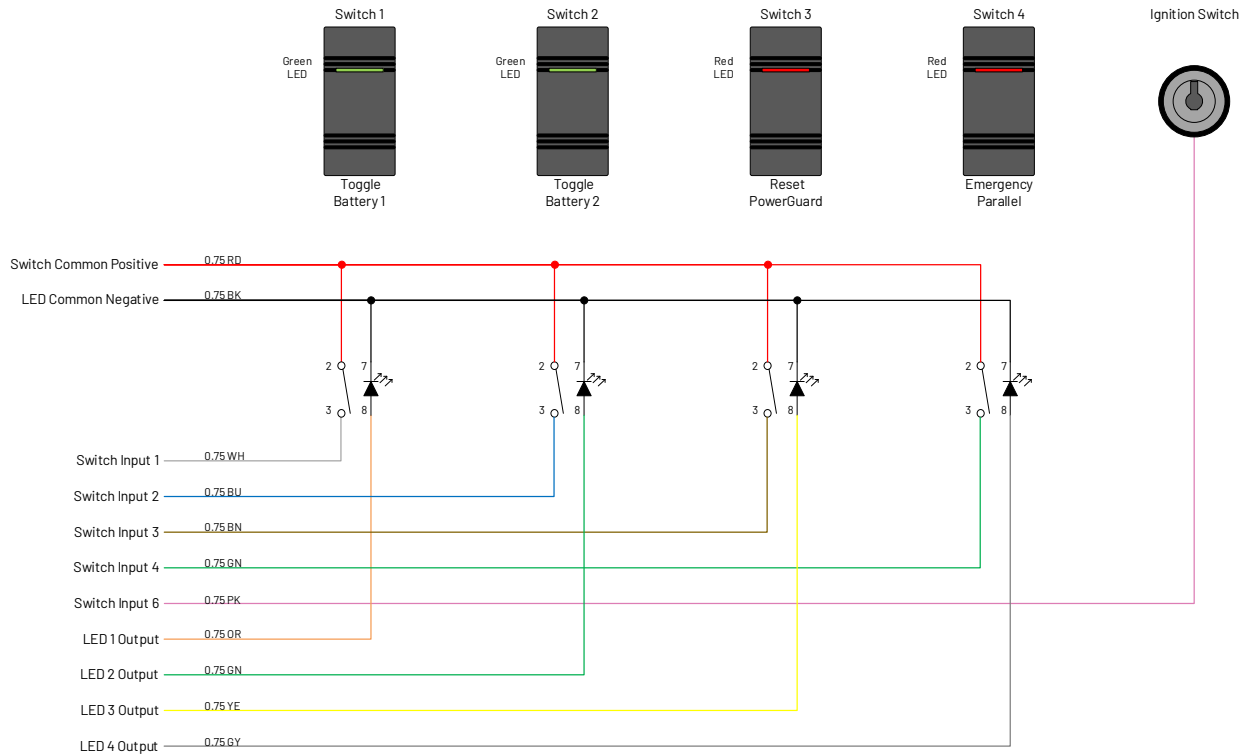

NOTES

FINAL CHECKS:

Once cabling is complete. We highly recommend following the checklist below before reconnecting the main battery cables

- **CAUTION!** Incorrect and reverse polarity may damage the system.
- **WARNING!** Reverse polarity connections to batteries may cause them to explode. Check all cabling before powering up the system.

PRE POWERUP-CHECKS:

- Check security of each component
- Check main battery cables against system diagrams
- Check main battery cables are correctly sized based upon rated loads
- Check tightness of all connections
- Ensure all live terminals are covered with rubber insulating boots
- Check all negative connections are secure

BATTERY CONNECTION:

Connect the batteries.

You will hear various clicks and clunks as the PowerBank Lite determines the position of contactors.

Depending on unit status the switch LEDs will light.

DIGITAL SIGNAL PROCESSING:

PowerBank Lite senses and processes voltages using a Digital Signal Processing (DSP) which filters out transient spikes and electrical noise preventing contactors connecting and disconnecting erroneously.

The DSP operation means that the PowerBank Lite will take time to respond to sudden changes in voltage, so it may appear that there is a time-lag between the voltage reaching a certain level and the PowerBank Lite reacting to it. This is normal operation.

PROGRAMMING

PowerBank Lite is factory shipped as a pre-programmed system. The standard operation of the switch inputs and LED outputs are as follows:

SWITCH 1:

If the engine battery is connected, pressing the switch will manually isolate it. If the engine battery is manually isolated, pressing the switch will reconnect it.

SWITCH 2:

If the auxiliary battery is connected, pressing the switch will manually isolate it. If the auxiliary battery is manually isolated, pressing the switch will reconnect it.

SWITCH 3:

Resets flat battery protection (PowerGuard) on both engine (B1) and auxiliary (B2) batteries, reconnects manual isolation.

SWITCH 4:

Emergency battery parallel. Pressing the switch will cause the engine and auxiliary batteries to be paralleled for a period of 50 seconds. This is to enable emergency starting of the vehicle in the event of a flat engine battery

SWITCH 6:

Ignition Input. When the ignition is 'On' this will inhibit disconnection of the engine battery (B1) isolation contactor. This is required to stop the possibility of the user isolating the engine battery with the engine running and potentially damaging the vehicle alternator or disabling vehicle safety systems.

- *Caution! Switches 1-4 must be momentary (On) Off operation.*

LED 1:

LED 1 is related to the engine battery (B1).

LED On Continuously: Battery connected.

LED Off = Manually isolated.

LED 2:

LED 2 is related to the auxiliary battery (B2).

LED On Continuously: Battery connected.

LED Off = Manually isolated.

LED 3:

LED 3 is related to the flat battery protection (PowerGuard).

LED Continuously On: Engine (B1) or Auxiliary (B2) Battery Isolated due to low battery voltage.

LED Off: Normal operation.

LED 4:

LED 4 is related to the split charge system.

LED Continuously On: Battery Parallel (split charging via contactor).

LED Off: No split charge is taking place.

Note: LED 5 & 6 are not currently used. —

Should the end user require custom programming, the PowerBank Lite can be supplied as an ECU only with external components as required. In this instance a 'Specifying Guide' will need to be completed by the specifying engineer. This should include (but not be limited to) the following information:

- Vehicle type
- Vehicle alternator rating (Amps)
- Auxiliary battery size (Ah) & type (e.g. Lead Acid / AGM)
- Maximum auxiliary battery bank loads
- Flat battery protection isolation voltage
- Battery split charge connect / disconnect voltages
- System switch inputs required

Please ensure all programming requirements and parameters and any customer training needs are addressed by your specifying engineer before taking delivery of the unit.

POWERBANK LITE OPERATION

PowerBank Lite has been developed as a total battery management product for 2 battery banks.

During normal operation the PowerBank Lite will monitor the voltages of both the engine and auxiliary batteries. Depending on these voltages it will carry out the following tasks:

1. Flat battery isolation (PowerGuard)

Should the engine battery discharge to below the pre-set threshold of 12.3V (24.6 for 24V operation), a 2-minute timer will activate. If the voltage remains below this threshold for the 2-minute period, the engine contactor will isolate. The red LED in switch 3 will also illuminate.

Should the Auxiliary battery discharge to below the pre-set threshold of 11.8V (23.6 for 24V operation), a 4-minute timer will activate. If the voltage remains below this threshold for the 4-minute period, the auxiliary contactor will isolate. The red LED in switch 3 will also illuminate.

To reset the flat battery protection on either battery bank, press switch 3. The relevant contactor will reconnect. At this point charge should be applied to the batteries by either starting the engine or use of an external charge source.

2. Split Charge (SmartBank)

Should the engine or auxiliary battery voltage be increased to above 12.6V (25.2 for 24V operation) for a period of 5 seconds the split charge contactor will connect and parallel the two battery banks enabling split charging between the pair. The red LED in switch 4 will also illuminate.

Should the battery pair voltage discharge to below 12.5V (25.0 for 24V operation) a 50 second timer will activate. If the voltage remains below this threshold for the 50-second period, the contactor will open separating the two battery banks.

3. Emergency Parallel

The PowerBank Lite has the ability to parallel both battery banks together to provide an emergency 'jump start' facility in the event of a flat engine start battery.

To operate the emergency parallel facility, press switch 4. The split charge contactor will connect for a period of 50 seconds and the LED will illuminate in the switch.

4. Battery Isolators

Using switches 1 and 2 enables user control of the manual battery isolators. This facility negates the need for additional battery isolation devices within the system. The switch LEDs provide user feedback as to whether the battery is manually connected or disconnected.

AFTER INSTALLATION

If you are unsure about any aspect please consult a suitably qualified engineer, your Dealer or Merlin Equipment Ltd before commissioning the unit.

PRODUCT SPECIFICATIONS

PowerBank Lite	
Part Number(s)	19-5110 (ECU Only) 19-5100 (12V 2 Batteries) 19-5101 (24V 2 Batteries)
ECU Dimensions (Excluding Cables)	141 x 93 x 48mm (W x L x H)
ECU Weight excluding cabling	0.35Kg
Voltage Rating	12 or 24V DC
Operational Input Voltage Range	6.5 to 36V DC
Operation Temperature Range (°C)	-25 to + 105°
Maximum Contactor Current	200A Continuous, 350A Peak
Current Consumption	11mA* <i>*Unit in idle state with no contactors or LEDs powered</i>
Maximum number of Battery Banks	2
Voltage Reading Range	0 to 19.3V or 38.6V (Dependant on 12 / 24V Setting)
Voltage Reading Accuracy	+/- 0.1V DC on 12V setting +/- 0.2V DC on 24V setting
LED Output	5V DC Source with 1K series limiting resistor
PC Communications	RJ11 – RS232 Communications

PRODUCT ACCESSORIES

Merlin Part Number	Description
19-5004	DataCell/PowerBank/PowerBank Combi Programming Kit
19-5010	Flat Battery / Isolator Contactor 12V
19-5011	Flat Battery / Isolator Contactor 24V
19-5014	Split Charge Contactor 12V
19-5015	Split Charge Contactor 24V
19-5018	Input Switch (On)-Off Momentary with Red LED
19-5019	Input Switch (On)-Off Momentary with Green LED
19-5111	Connector J1 Loom – 2m
19-5112	Connector J2 Loom – 2m
10-4012	Cable Cap Insulation Boot 2 – 2/0 AWG Red
10-4013	Cable Cap Insulation Boot 2 – 2/0 AWG Black
HWC/FHMG/1	Mega Fuse Holder
HWC/FME/200	200A Mega Fuse
HWC/ATOF/KIT	ATO Single Blade Fuse Holder
HWC/BF2	2 Amp Blade Fuse

WARRANTY

PowerBank Lite is warranted to be free of defects caused during manufacture for a period of 2 years from purchase. The warranty may be invalidated if the device has been altered, misused, installed incorrectly or operated in adverse conditions described in the "Precautions" section of this document.

What does this warranty cover and how long does it last? This Limited Warranty is provided by Merlin Equipment Limited. ("Merlin") and covers defects in workmanship and materials in your PowerBank Lite. This warranty period lasts for 24 months from the date of purchase at the point of sale to you, the original end user customer, unless otherwise agreed in writing (the "Warranty Period"). You will be required to demonstrate proof of purchase to make warranty claims.

This Limited Warranty is transferable to subsequent owners but only for the unexpired portion of the Warranty Period. Subsequent owners also require original proof of purchase as described in "What proof of purchase is required?"

What will Merlin do? During the Warranty Period Merlin will, at its option, repair the product (if economically feasible) or replace the defective product free of charge, provided that you notify Merlin of the product defect within the Warranty Period, and provided that Merlin through inspection establishes the existence of such a defect and that it is covered by this Limited Warranty.

Merlin will, at its option, use new and/or reconditioned parts in performing warranty repair and building replacement products. Merlin reserves the right to use parts or products of original or improved design in the repair or replacement. If Merlin repairs or replaces a product, its warranty continues for the remaining portion of the original Warranty Period or 90 days from the date of the return shipment to the customer, whichever is greater. All replaced products and all parts removed from repaired products become the property of Merlin.

Merlin covers both parts and labour necessary to repair the product and return shipment to the customer via a Merlin-selected non-expedited surface freight within the contiguous United States and Canada. Alaska, Hawaii and outside of the United States and Canada are excluded. In Europe, this is the EMEA. Contact Merlin Customer Service for details on freight policy for return shipments from excluded areas.

How do you get service? If your product requires troubleshooting or warranty service, contact your merchant. If you are unable to contact your merchant, or the merchant is unable to provide service, contact Merlin directly at: Merlin Equipment Ltd, Clyst Court, Hill Barton Industrial Estate, Exeter, Devon, EX5 1SA, United Kingdom. Tel: +44 (0)1202 697979.