

# POWERGUARD LITE

PowerGuard Lite provides basic flat battery protection. After voltage has reached a preset value for a preset time, the unit will disconnect batteries to prevent damage through excessive discharge and retain enough power to ensure engine restarting. After activation, batteries are reconnected using a dash-mounted press switch.

PowerGuard Lite is designed for a single battery bank and is best suited to protecting an engine start battery. The contactor supplied is designed for installation adjacent to the battery, can handle up to 125A continuously, and is IP66 rated. The CPU and dashboard switch should be mounted within the interior. Set-up can be performed using trim-pots inside the CPU.

PowerGuard Lite is also available in OEM versions and component parts for building into control boxes and panels, or for serial production line environments.

- **Damage prevention**  
by isolating batteries before they go flat to ensure engine start.
- **Cost-effective**  
by preventing expensive breakdowns and premature battery failure.
- **Fully programmable**  
with adjustable voltage and time thresholds.
- **Reset switch supplied**  
designed to be dash-mounted with a built-in warning LED.
- **Low power consumption**  
to maximise the residual power in the battery after disconnection.

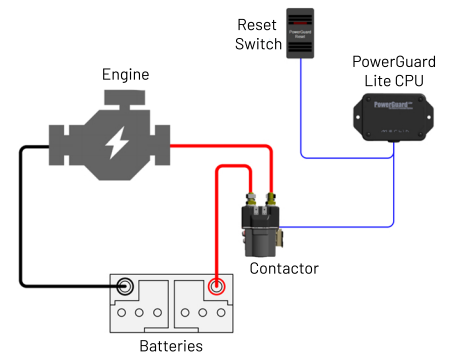

PART#	19-4015	19-4016
MODEL	12V	24V
NOMINAL VOLTAGE	12VDC	24VDC
MAXIMUM CURRENT (CRANKING)	600A	600A
MAXIMUM CURRENT (5 MINS)	200A	200A
MAXIMUM CURRENT (CONTINUOUS)	125A	125A
POWER CONSUMPTION	<5MA	<3MA
CPU WEIGHT EX CABLES (G)	103.5	103.5
CPU DIMENSIONS EX CABLES (MM)	110 X 60 X 30	110 X 60 X 30
CONTACTOR WEIGHT (G)	350	350
CONTACTOR DIMENSIONS (MM)	91 X 50 X 39	91 X 50 X 39
RESET SWITCH WEIGHT (G)	24	24
RESET SWITCH DIMENSIONS (MM)	37 X 22	37 X 22
COMPLIANCE	EMC2002/95/EC, CE, ISO7637-2, SAE J1171	EMC2002/95/EC, CE, ISO7637-2, SAE J1171

All specifications are provided in best possible faith but may be subject to change without notice. All business is transacted according to our Standard Terms & Conditions, a copy of which is available upon request.