

# **Abso DC to DC Battery Charger**

**12V 30A (DMT1230)  
12V 50A (DMT1250)  
24V 30A (DMT2430)**

## **Owner's Manual**

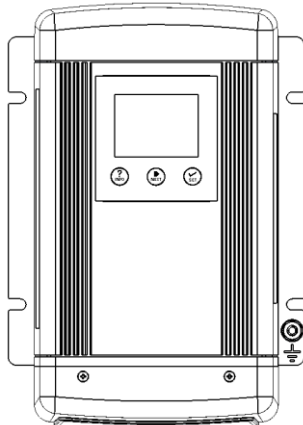

**KISAE<sup>SM</sup>**

For safe and optimum performance, the **KISAE Abso DC to DC Battery Charger** must be used properly. Carefully read and follow all instructions and guidelines in this manual and give special attention to the **CAUTION** and **WARNING** statements.

## PLEASE KEEP THIS MANUAL FOR FUTURE REFERENCE

### Disclaimer

While every precaution has been taken to ensure the accuracy of the contents of this guide, **KISAE Technology** assumes no responsibility for errors or omissions. Note as well that specifications and product functionality may change without notice.

### Important

Please be sure to read and save the entire manual before using your **KISAE DC to DC Battery Charger**. Misuse may result in damage to the unit and/or cause harm or serious injury.

### Product Numbers

<b>DMT1230</b>	<b>Abso DC to DC Battery Charger 12V 30A</b>
<b>DMT1250</b>	<b>Abso DC to DC Battery Charger 12V 50A</b>
<b>DMT2430</b>	<b>Abso DC to DC Battery Charger 24V 30A</b>

### Document Part Number

MU DMT1230 Rev D

### Service Contact Information

Email: [info@kisaetechnology.com](mailto:info@kisaetechnology.com)

Phone : 1 877 897-5778

Web : [www.kisaepower.com](http://www.kisaepower.com)

### FCC and CE EMC INFORMATION

This equipment has been tested and found to comply with the limits for a Class B digital device, pursuant to part 15 of the FCC Rules and comply with the limits for CE EMC. These limits are designed to provide reasonable protection against harmful interference in a residential installation. This equipment generates uses and can radiate radio frequency energy and, if not installed and used in accordance with the instructions, may cause harmful interference to radio communications. However, there is no guarantee that interference will not occur in a particular installation. If this equipment does cause harmful interference to radio or television reception, which can be determined by turning the equipment off and on, the user is encouraged to try to correct the interference by one or more of the following measures:

- Re-orient or re-locate the receiving antenna.
- Increase the separation between the equipment and the receiver.
- Connect the equipment into an outlet on a circuit different from that to which the receiver is connected.
- Consult the dealer or an experienced radio/TV technician for help.

### LIMITATIONS ON USE

Do not use in connection with life support systems or other medical equipment or devices.

**WARNING:** This product can expose you to chemicals, including Di (2-ethylhexyl) phthalate (DEHP) which is known to the State of California to cause cancer, birth defects or other reproductive harm. For more information, go to [www.p65warnings.ca.gov](http://www.p65warnings.ca.gov)

**ADVERTENCIA** Este producto puede exponerlo a químicos, incluyendo el ftalato de bis (2-etilhexilo) (DEHP) conocido por el estado de California como causante de cáncer, defectos de nacimiento, u otros daños reproductivos. Para obtener más información, entre a [www.p65warnings.ca.gov](http://www.p65warnings.ca.gov)

## Table of Contents

1.	INTRODUCTION .....	5
2.	PRODUCT DESCRIPTION .....	5
3.	UNDERSTANDING THE UNIT.....	5
4.	INSTALLING THE CHARGER.....	8
5.	CONNECTING THE CHARGER .....	8
6.	UNIT OPERATION .....	10
7.	SPECIFICATIONS.....	16
8.	WARRANTY .....	17
	Appendix A1 .....	18
	Appendix A2 .....	20
	Appendix A3 .....	22

### IMPORTANT SAFETY INFORMATION

This section contains important safety information for the **KISAE Abso DC to DC Battery Charger**. Each time, before using the unit, READ ALL instructions and cautionary markings on or provided with the unit, and all appropriate sections of this guide. The unit contains no user-serviceable parts. See Warranty section for how to handle product issues.

#### **WARNING: Fire and/or Chemical Burn Hazard!**

Do not cover or obstruct any air vent openings and/or install in a zero-clearance compartment.

#### **WARNING: Failure to follow these instructions can result in death or serious injury. Keep away from children!**

- When working with electrical equipment or lead acid batteries, have someone nearby in case of an emergency.
- Study and follow all the battery manufacturer's specific precautions when installing, using and servicing the battery connected to the charger.
- Wear eye protection and gloves.
- Avoid touching your eyes while using this unit.
- Keep fresh water and soap on hand in the event battery acid comes in contact with eyes. If this occurs, cleanse right away with soap and water for a minimum of 15 minutes and seek medical attention.
- Batteries produce explosive gases. **DO NOT** smoke or have an open spark or fire near the system.
- Keep unit away from moist or damp areas. Never expose unit to snow, water etc.
- Avoid dropping any metal tool or object on the battery. Doing so could create a spark or short circuit which goes through the battery or another electrical tool that may create an explosion.

#### **WARNING: Explosion hazard!**

- Do not use the unit in the vicinity of flammable fumes or gases (such as propane tanks or large engines).
- Avoid covering the ventilation openings. Always operate unit in an open area.
- Prolonged contact to high heat or freezing temperatures will decrease the working life of the unit.
- The **DMT2430** unit is designed for use on **24V House Battery System** only. Do not use it on 12V House Battery System.

#### **CAUTION:**

- This appliance is not intended for use by persons (including children) with reduced physical, sensory or mental capabilities, or lack of experience and knowledge, unless they have been given supervision or instruction concerning use of the appliance by a person responsible for their safety.
- Children should be supervised to ensure that they do not play with the appliance.
- Do not charge non-rechargeable batteries because of the danger of eruption.
- During charging, batteries should be placed in a ventilated area.
- The battery terminal not connected to the chassis has to be connected first.
- The other connection is to be made to the chassis, remote from the battery and fuel line. The battery charger is then to be connected to the supply mains (household power).
- After charging, disconnect the battery charger from the supply mains. Then remove the chassis connection and then the battery connection.
- Only allow children at least 8 years old to use the battery charger. Give sufficient instruction so that the child is able to use the battery charger in a safe way and explain that it is not a toy and must not be played with.
- Examine the battery charger regularly for damage, especially the cord, plug and enclosure. If the battery charger is damaged, it must not be used until it has been repaired.

## 1. INTRODUCTION

Thank you for purchasing the **KISAE Abso DC to DC Battery Charger**. With our state of the art, easy to use design, this product will offer you reliable service for providing a multi-stage, multi-input battery charger to charge the different types of batteries you have installed in either your home, boats, RV caravan, 4WD or commercial vehicle. This manual will explain how to use this unit safely and effectively.

## 2. PRODUCT DESCRIPTION

The DC to DC Battery Charger includes the items list below:

- Base unit

Model	Maximum Output Rating	Battery Input Voltage	Maximum Solar Input
<i>DMT1230</i>	12V 30A	12V or 24V (Auto Ranging)	50Voc, 30A
<i>DMT1250</i>	12V 50A		
<i>DMT2430</i>	24V 30A		

- Owner's manual

## 3. UNDERSTANDING THE UNIT

The DC to DC Battery Charger is a fully automatic multi-stage, multi-input battery charger with the ability to charge from either an alternator linked to a battery, or via solar power with its built-in Maximum Power Point Tracking (MPPT) Solar Controller. With two inputs available, the house battery will be charged from either the engine while underway, or via the solar panels when stationary. The process to choose either engine or solar is fully automatic and both functions are controlled from within the unit itself without the need for external relays.

During normal operation the DC to DC Battery Charger will do a full charge cycle to float stage on the House Battery Bank with ability to choose either GEL, AGM, Flooded, Custom Programmable or Lithium. Once the float stage is reached the charger transitions to a power supply mode to support any on-board DC loads.

### **Multi-stage Charging Process – GEL, AGM, Flooded & Program Modes**

The DC to DC Battery Charger is a fully automatic, set and forget charger. It is designed to quickly and accurately recharge your deep cycle batteries utilizing charger algorithms that help to maximize the life of your specialized deep cycle batteries.

The DC to DC Battery Charger features multi-stage smart charging technology that enables the charger to be connected to your House Battery Bank permanently. With the input of multiple sources, you can be assured of charging your batteries whenever underway; or when the sun is shining on your solar array.

As dictated by battery manufacturer recommendations, deep cycle batteries require a multi-stage charge sequence for perfect, fast and accurate charging. The DC to DC Battery Charger delivers three primary charge stages:

**Stage 1 – Bulk or Boost charge:** The battery is charged at full rated output current of the charger (as per the setting) until the battery reaches its final charging voltage, known as its absorption voltage. In this step, around 80% of the battery is recovered as fast as possible.

**Stage 2 – Absorption Charge:** With the charger voltage held steady, the remaining 20% of the battery is replaced with the charger allowing the current to taper off as the battery approaches full charge.

**Stage 3 – Float:** In the float stage the charger voltage is lowered and held at a constant and safe predetermined level. This prevents the battery from being overcharged, yet allows the charger to supply enough current to make up for the self-discharge losses of the battery, while supporting any additional loads connected to the battery (such as DC lighting and refrigerators). This stage allows the charger to be used as a DC power supply.

A full recharge cycle will occur when the House Battery Bank voltage drops to below 12.5Vdc on *DMT1230*, *1250* or 25.0Vdc on *DMT2430*.

### **Lithium Charging Process**

The DC to DC Battery Charger has a specific charging profile for Lithium batteries. It has its own charging voltage and current settings that needs to be set by the user. It also requires the user to set the charger termination current ("L" setting) to pass from Absorption to Float stage. Once the user defined charge voltage is reached, the charger will start reducing the current output and the charging process will terminate when the charging current drops to the set termination ("L") current. This can take anywhere between 3 to 25 minutes, depending on the capacity (size) of the battery bank and its initial state of charge. The unit will then act as a power supply to support additional loads connected to the battery. A bulk re-start will occur when the House Battery Bank voltage drops to below 13.3Vdc on *DMT1230/DMT1250* or 26.6Vdc on *DMT2430*.

## Smart Charging Feature

The DC to DC Battery Charger will regulate its output based on the loads connected to your House Battery Bank. This function is important to maintain the life of your battery banks as some other battery chargers mistake loads for discharge and continue to keep the batteries in the bulk or absorption stage for extended periods of time, which will damage the battery bank. The DC to DC Battery Charger has two methods of load-based regulation to ensure your battery charger transitions to float stage when it should do so.

### House Battery Bank Charging Algorithm (3 stages)

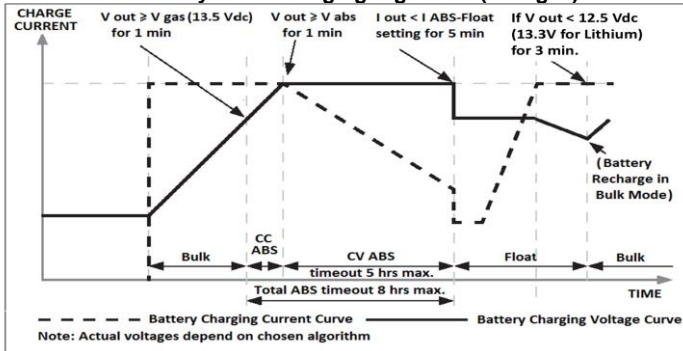

**Note: For DMT2430, all the voltage rating on the above graph are doubled**

## House Battery Bank (CH1) Charging Voltage

DMT1230, DMT1250 Charging Voltage Setting (See Note 1 for DMT2430)			
Battery Type	Bulk/Absorption	Float (Note 2)	Equalization
GEL	14.4V	13.7V	N.A.
AGM	14.6V	13.6V	N.A.
Flooded	14.4V	13.3V	15.5V (Note 3)
Lithium	13.9-14.6V (0.1V step)	13.5-14.2V (0.1V step)	N.A.
Program (Custom Settings)	13.8-14.8V (0.1V step)	13.0-13.8V (0.1V step)	N.A.

Note 1: For DMT2430, all the voltage rating on the above chart are doubled.

Note 2: Charger is acting as a power supply with selected constant output voltage and preset maximum output current.

Note 3: Equalization setting can only be used on flooded battery type selection only. See more details on "Procedure to Equalize the Flooded Battery"

For Concorde™ branded batteries (Lifeline, Sun Xtender) use flooded setting and consult battery supplier for equalization recommendations.

## Bulk/Absorption, Absorption-Float Stage Current Setting

The Bulk/Absorption (Bulk/Abs) and Absorption-Float (Abs-Float) Stage current settings are based on the House Battery Bank size. Typically and for maximum lifespan of the sealed and non-sealed lead acid battery bank, it is recommended the maximum Bulk/Abs ("h") current setting should not be more than 1/5 of its total capacity in Ah (e.g. select 30A or lower when a 150Ah battery bank is used). For Lithium battery bank, see section "Lithium House Battery Bank Current Setting".

Battery Bank Size (Min) in Ah	DMT1230 (12V House Battery Bank), DMT2430 (24V House Battery Bank)			
	25	50	100	150 or higher
Max. Current Setting ("h") in A	5	10	20	30

Battery Bank Size (Min) in Ah	DMT1250 (12V House Battery Bank)									
	25	50	75	100	125	150	175	200	225	250
Max. Current Setting ("h") in A	5	10	15	20	25	30	35	40	45	50

Once the Bulk/Abs current is selected, the Abs-Float Stage ("L") current can be selected. It is recommended to select 1/10 of the Bulk/Abs current as the Abs-Float stage current setting.

DMT1230, 2430 Available Current Setting (A)				
Bulk/Abs ("h")	5	10	20	30
Abs-Float ("L")	0.3/0.5/1	0.5/1/2	1/2/4	1.5/3/6

DMT1250 Available Current Setting (A)										
Bulk/Abs ("h")	5	10	15	20	25	30	35	40	45	50
Abs-Float ("L")	1/1.5/2	1/1.5/2	1/1.5/2	2/3/4	2/4/5	3/4/6	3/5/7	4/6/8	4/6/9	5/7/10

Note: The battery will start the full recharge cycle again when the battery terminal voltage drops to 13.3Vdc on DMT1230/DMT1250, and 26.6Vdc on DMT2430. If a DC load is always ON and connected to the battery bank, a higher Absorption-Float charging current is recommended. If in doubt of the "L" setting, use the highest available current setting for battery protection.

### Lithium Type House Battery Bank Voltage and Current Setting:

**WARNING: FIRE HAZARD.** When choosing the Lithium Battery type, you can set to a wide range of charge/float voltage. Please consult the battery manufacturer on all the values. Using the wrong voltage setting may overcharge and damage the battery and may cause a fire.

The Charging Voltage, Float Voltage, Charging Current and Termination Currents, are user selectable. Consult the Lithium battery manufacturer for the maximum allowable charging voltage and current. The Termination Current can be selected to determine when to start passing to the Float stage. See more details in Appendix A2.

DMT1230, DMT2430 Available Lithium Voltage (V) and Current Setting (A)				
Charging Voltage	DMT1230: 13.9 – 14.6Vdc (0.1V step),		DMT2430: 27.8 – 29.2Vdc (0.2V step)	
Float Voltage	DMT1230: 13.5 – 14.2Vdc (0.1V step),		DMT2430: 27.0 – 28.4Vdc (0.2V step)	
Charge Current (“h”)	5	10	20	30
Termination Current (“L”)	0.3/0.5/1	0.5/1/2	1/2/4	1.5/3/6

DMT1250 Available Lithium Voltage (V) and Current Setting (A)										
Charging Voltage	13.9 – 14.6Vdc (0.1V step)									
Float Voltage	13.5 – 14.2Vdc (0.1V step)									
Charge Current (“h”)	5	10	15	20	25	30	35	40	45	50
Termination Current (“L”)	1/1.5/2	1/1.5/2	1/1.5/3	2/3/4	2/4/5	3/4/6	3/5/7	4/6/8	4/6/9	5/7/10

Note: The battery will start the full recharge cycle again when the battery terminal voltage drops to 13.3Vdc on DMT1230/DMT1250, and 26.6Vdc on DMT2430. If a DC load is always ON and connected to the battery bank, a higher Absorption-Float charging current is recommended. If in doubt of the “L” setting, use the highest available current setting for battery protection.

### Program Type House Battery Bank Voltage and Current Setting:

**WARNING: FIRE HAZARD.** When choosing the Program Battery type, you can set to a wide range of charge/float voltage. Please consult the battery manufacturer on all the values. Using the wrong voltage setting may overcharge and damage the battery, and may cause a fire.

The Bulk Voltage, Float Voltage, Charging Current and Absorption-Float (Abs-Float) Current are user selectable. Consult the battery manufacturer for the maximum allowable voltage and current. The Absorption-Float current can be selected to determine when to start passing to the Float stage (with 3 stages setting) or to terminate the charging process (with 2 stages setting). See more details in Appendix A3.

DMT1230 Available Charging Voltage Setting (V) and Charging Current Setting (A)				
Bulk Voltage	13.8 – 14.8Vdc (0.1V step)			
Float Voltage	13.0 – 13.8Vdc (0.1V step)			
Charging Current (“h”)	5	10	20	30
Abs-Float Current (“L”)	0.3/0.5/1	0.5/1/2	1/2/4	1.5/3/6

Note: For DMT2430, all the voltage rating on the above chart are doubled.

DMT1250 Available Bulk Charge Voltage Setting (V) and Charge Current Setting (A)										
Bulk Charge Voltage	13.8 – 14.8Vdc (0.1V step)									
Float Voltage	13.0 – 13.8Vdc (0.1V step)									
Charge Current (“h”)	5	10	15	20	25	30	35	40	45	50
Abs-Float Current (“L”)	1/1.5/2	1/1.5/2	1/1.5/3	2/3/4	2/4/5	3/4/6	3/5/7	4/6/8	4/6/9	5/7/10

Note: The battery will start the full recharge cycle again when the battery terminal voltage drops to 12.5Vdc on DMT1230/DMT1250 and 25.0Vdc on DMT2430. If a DC load is always ON and connected to the battery bank, a higher Absorption-Float current is recommended. If in doubt of the “L” setting, use the highest available current setting for battery protection.

## 4. INSTALLING THE CHARGER

**WARNING:** KISAE Technology recommends that all wiring be done by a certified technician or electrician to ensure adherence to the applicable electrical safety regulations and installation codes. Failure to follow these instructions can damage the unit and could also result in personal injury or loss of life.

**CAUTION:** Before beginning your unit Installation, please consider the following:

- The unit should be used or stored in an indoor area away from direct sunlight, heat, moisture or conductive contaminants.
- When placing the unit, allow a minimum of three inches of space around the unit for optimal ventilation.

### Mounting the Charger:

- Choose an appropriate mounting location.
- For installing in an indoor location, the unit should be mounted vertically (with the battery terminals facing downwards). This provides the best thermal performance and drip protection. The unit should NOT be mounted upside down.
- For installing in a boat or marine environment, the unit should only be mounted vertically (Battery Terminals facing downwards) to provide adequate drip protection.
- Use the base of the charger as a mounting template to mark the positions of the fixing screws.
- Drill the 4 fixing holes and place the Charger in position and fasten the unit to the mounting surface.  
*Note: The charger is designed to be permanently mounted.*

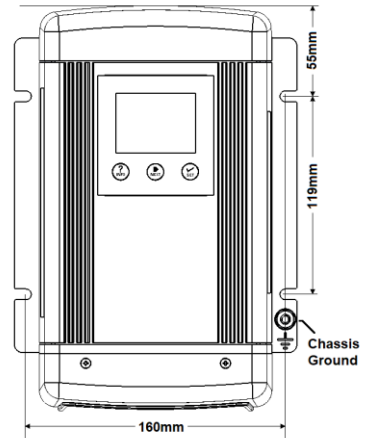

## 5. CONNECTING THE CHARGER

### Chassis Ground Connection:

**DANGER:** The unit chassis has to be grounded properly. Never operate the Charger without proper grounding. Failure to do so will result in death or serious injury. Ground connection to the charger must comply with all local and application-specific codes and ordinances.

- Connect the unit's chassis ground to the common ground point through the ground stud "Chassis Ground" located near one of the unit mounting slots.

### DC Inputs and Output Wiring:

**WARNING:** The DC wiring used must be of appropriate size. An individual over-current protection device usually within 7 inches (17.8cm) of each battery bank is required. A DC disconnect switch is also recommended. Both devices must be rated for DC voltage and current to withstand the short circuit current available from the connected battery bank. Both devices must match with the size of the DC wiring.

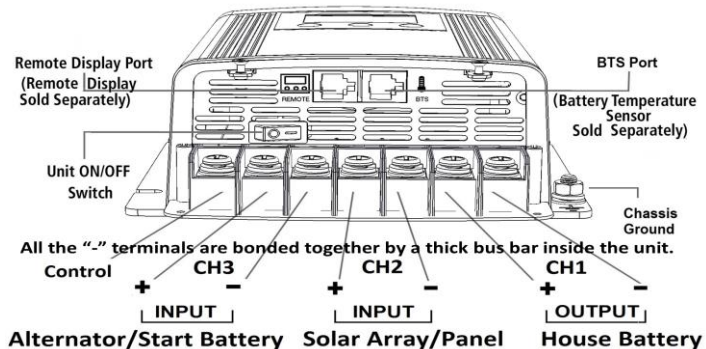



## Recommended Cable Length, Size and Fuse Protection:

Unit Connection	Recommended Fuse/Circuit Breaker Size, Wire Length and Size	
	DMT1230, 2430	DMT1250
CH 1 House Battery Bank	40A, <5 ft, AWG #8 / 10mm <sup>2</sup>	60A, <5 ft, AWG #6 / 16mm <sup>2</sup>
CH 2 Solar Array/Panel (Note1)	12V/300W: 20A, <20 ft, AWG #12 / 4mm <sup>2</sup>	40A, <20 ft, AWG #8 / 10mm <sup>2</sup>
	24V/300W:10A <20 ft, AWG #14 / 1.5mm <sup>2</sup>	20A, <20 ft, AWG #12 / 4mm <sup>2</sup>
CH 3 Alternator/Starter 12V Input	50A, <5 ft, AWG #6 / 16mm <sup>2</sup>	60A, <5 ft, AWG #6 / 16mm <sup>2</sup>
	24V Input	25A, <5 ft, AWG #10 / 6mm <sup>2</sup>

Note 1: The 12V/300W and 24V/300W solar panel sizes are for reference only and the related fuse size, length and wire gauges vary with the solar panel size accordingly. Please consult the solar panel manufacturer for details.

Note 2: Fuse or Circuit Breaker installed should be no greater than 7" from battery.

Note 3: Keep the connection between the House Battery bank and the charger as short as possible.

- Detach the plastic cover of the DC wiring compartment by removing the two screws on its top.
- Connect the CH1 "+" terminal in series to one of the over-current protection device, the disconnection device, and finally to the "+" terminal of the House Battery bank
- Connect the CH1 "-" terminal to the negative terminal of the House Battery Bank.
- Make all the "+" and "-" wire connections on CH2 (Solar Array/Panel) and CH3 (Alternator/Start battery). See more details in "DC Inputs and Output Wiring".
- Tighten all the bolts of the charger terminals to 4.0-5.0 N-m (35-45 lb-in) of torque. Do not over tight as this may result in damage to the charger.
- Replace the plastic cover to its original position, and secure the two screws on its top.

Note: All the charger's negative "-" terminals are bonded together inside the unit with a thick bus bar, and isolated from the chassis stud terminal ground.

## Unit Wiring: Connecting the unit the right way

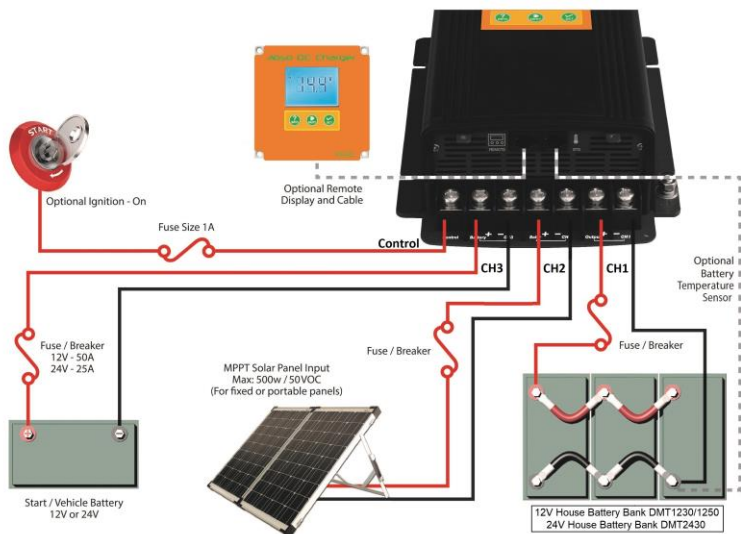

Note: This diagram is for a reference only. No cables, fuse/breakers, batteries or solar panels are supplied with this unit. Local rules and regulations should be followed when installing this unit.

## BTS Port Connection (optional Battery Temperature Sensor sold separately)

- To install the Battery Temperature Sensor (BTS), simply connect the RJ12 plug from the sensor to the 'BTS' port located next to the Remote Display Port on the unit.
- Connect the other end of the temperature sensor (ring terminals/lug) to the negative terminal of the main house battery bank.

**NOTE:** For lithium and Program battery setting, the temperature sensor is not required and it would be ignored if installed.

## 6. UNIT OPERATION

### Unit ON/OFF

A Unit ON/OFF switch is located at the DC Input/Output panel of the unit. Switch to ON position to activate the charger and switch to OFF position to turn the unit off when not in use.

### Understanding the Charging Mechanism

The Charger is powered by the battery connected to House Battery (CH1). The unit requires a minimum of 8Vdc to operate. The unit display will turn off automatically to save power when the two Input channels CH2 and CH3 are out of operating range.

### Operating from an Alternator/Start Battery (CH3)

Normal Operation	Alternator/Start Battery (CH3)	
	12V INPUT Source	24V INPUT Source
Input Voltage Range	10.5V – 16.0V	21.0– 32.0V
Normal Start-Up Voltage (Note A)	> 13.2V	> 26.4V
Normal Under Voltage Recovery Voltage (Note A)	> 12.8V	> 25.6V
Control Terminal	> 10.5V forces CH3 input to the Low Start-Up and Low-Under Voltage recovery settings.	
Low Start-Up Voltage (using Control Terminal or Manual Over-ride setting) (Note B)	> 12.3V	> 24.6V
Low Under Voltage Recovery Voltage (Note B)	> 12.0V	> 24.0V
De-Rated Voltage (with load) (Note C)	11.5V	23.0V
Under Voltage Shutdown (with load)	10.5V	21V
Over Voltage Shutdown	16.0V	32V
Over Voltage Recovery	15.5V	31V
Input Battery System Reset Voltage (Note D)	< 7V	< 7V
Maximum Input Current (CH3)	DMT1230/2430: 30A DMT1250: 50A	DMT1230/2430: 30A DMT1250: 50A

**Note A:** When the battery is charging through CH3 with normal operation (not through either manual or automatic override setting), the charger will charge for 3 minutes, it will then rest for 5 seconds to verify the CH3 Input voltage.

During the 5 seconds rest period, if the measured voltage is > Normal Under Voltage Recovery Voltage (> 12.8Vdc on a 12V Input system or > 25.6Vdc on a 24V Input system), the unit will continue the charging cycle through CH3.

If the measured voltage on CH3 is < Normal Under Voltage Recovery Voltage (< 12.8Vdc on a 12V Input system or < 25.6Vdc on a 24V Input system), the unit will switch back to charge from CH2 (PV) until CH3 returns to Normal Start-Up Voltage (13.2V on a 12V Input System and 26.4V on a 24V Input system).

Also, during the 3 minutes charging process, if the measured terminal voltage drops below the Under Voltage de-rate voltage (11.5V for a 12V Input system, 23V for a 24V Input system), the charger will start to de-rate the output current. This function is used to compensate for the use of long or thin wire between the Input Battery System and the unit terminals. If the input voltage continues to drop below the Under-Voltage Shutdown Voltage (10.5V for a 12V Input system and 21V for a 24V Input system), the charging process will terminate and the unit will switch back to charge from CH2 (PV). It will only switch back to CH3 if the CH3 voltage returns to 13.2V on a 12V Input system or 26.4V on a 24V Input system.

**Note B:** When the unit has activated the battery charging process using the Control terminal or using the Manual Override through the unit setting, the input voltage specification is reduced. It has the same charging process but with the Low Start-Up Voltage set to > 12.3V (from 13.2V) on a 12V Input system and > 24.6V (from 26.4V) on a 24V Input system. This feature is designed to be used for vehicles fitted with "Smart Alternators".

If the measured voltage on CH3 is <12.0 Vdc (<24Vdc on a 24V Input system), the unit will disconnect from the vehicle source and switch back to charge from CH2 (solar if installed) until the CH3 voltage returns to >12.3Vdc on a 12V Input System (>24.6V on a 24V Input system).

The Low Under Voltage Recovery Voltage is set to > 12V (from 12.8V) on a 12V Input system and > 24V (from 26.4V) on a 24V Input system. During the 5 second rest period, if the input voltage returns above 12V/24V, it will continue the charging process and if the input voltage does not return to > 12V/24V, it will switch back to charge from the Solar - CH2 (if connected) until the Start - CH3 input has returned to the Low Start-Up voltage of 12.3V on a 12V Input system and 24.6V on a 24V Input system.

**Note C:** During the 3 minutes charging process, if the measured terminal voltage drops to below the Under Voltage de-rated limit (11.5V for a 12V Input system, 23V for a 24V Input system), the charger will start to de-rate the charger current. This function is used to compensate for the use of long or thin cable between the Input Battery System and the unit terminals. If the voltage continues to drop to below the Under-Voltage Shutdown limit of (10.5V for a 12V Input system and 21V for a 24V Input system), the charging process will terminate and the unit will switch back to charge from CH2 (Solar if installed). It will only switch back to CH3 if the CH3 voltage returns to 13.2V on a 12V Input system and 26.4V on a 24V Input system.

**Note D:** The CH3 DC Input (Alternator/Start Battery Input) can accept a 12V or 24V Input battery with an alternator system. When the unit is first connected, the unit will measure the input voltage. If the voltage is > 17V, it will assume it is connected to a 24V Input Battery/Alternator system. If the voltage detect is < 17V, it will assume it is connected to a 12V Input Battery/Alternator system. Once detected, it will store this into the microprocessor and it will only be erased if the Input battery is disconnected or if the measured Input Voltage drops to < 7Vdc.

### Operating from an PV Solar Array/ Panel (CH2)

Normal Operation	PV Solar Array/Panel (CH2)
PV Input Voltage Range	14.5 - 50V
PV Input Under Voltage Shutdown	< 14.5V
PV Input Under Voltage Recovery	15.0V
PV Input Over Voltage Shutdown	> 50.0V
PV Input Over Voltage Recovery	≤ 48.0V
PV Charging Mechanism	MPPT type (approx. 97% efficiency)
Maximum Input Current	30A (*Note)

**\*Note:** The charger limits the input current of CH2 to 30A maximum. If a 12V solar panel is used, the maximum solar input power is around 500W. You can however "overdrive" the MPPT controller. Please note that doing this is partially an economic decision. You can install more power than the controller can use and this will contribute to better power availability. KISAE suggests a total maximum overdrive of 20% (total 600w). The extra solar panel power can compensate for cloudy (or intermittent sunny) days and around the dawn and sunset of all the days, so as to harvest more solar energy.

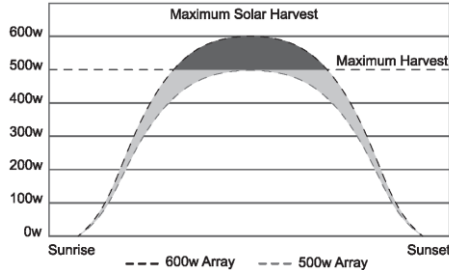

Note: Above chart is based on the use of 12V 600W solar panel array.

### Understanding the Display function during normal operation

Digital Display	
Display	LCD Digital Display with back lighting
Display Info for CH1:	Battery Voltage, Charging Current, Charging Status
Display Info for CH2:	PV Solar Array/Panel Input Voltage
Display Info for CH3:	Alternator/Start Battery Input Voltage
Fault/Warning	Error code E01-E07, Warning A01-02
'CH3' Icon Flashing	CH3 >13.2V/12.3V or >26.4/24.6V @ Norm./Prior. mode respect., and not charging from alternator yet
'CH3' Icon Solid	Charging from Alternator/Start Battery CH3
'CH2' Icon Flashing	CH2 > 14.5V and not charging from solar array
'CH2' Icon Solid	Charging from PV Solar Array/Panel CH2

- During normal operation, the display shows alternately the House Battery Bank Voltage (V), Charging Current (A) and Charging Stage Status ('bul' = Bulk, 'Abs' = Absorption, 'Ful' = Float) of the CH1 output. When the 'INFO' button is pressed once, it displays the other channel's CH2, CH3 Input voltage.
- CH3 icon flashes when the input voltage is above the Start-Up Voltage (i.e. >13.2V/12.3V on 12V CH3 battery system), or >26.4/24.6V on 24V CH3 battery system under Normal/Priority mode respectively), and it is not the charging source of the House Battery bank yet. It will change to solid when CH3 becomes the charging power source.
- CH2 icon flashes when the input voltage is above the Flashing Voltage (> 14.5V) and it is not the source to charge the battery. It will change to solid when CH2 becomes the charging power source.
- During normal operation, every time the 'INFO' button is pressed once, the display will scroll through and show 'CH1', 'CH2 & 'CH3' voltage for 3 seconds and it will return to the normal display automatically. If CH2 or CH3 is not connected, it will show 0V.
- The display will remain ON when either one or both CH2 & CH3 inputs are available. The display will turn off if CH2 or CH3 is not available for a while (several seconds).
- During the equalization mode (on flooded battery only), the numerical section on the display will show a flashing 'Eq' indicating the equalization process is in progress and it will not show both the battery voltage and the charging current.

### Understanding the Function Key Icons on Display

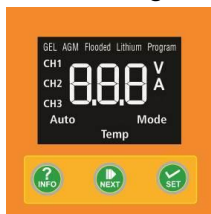

**CH1** - Display is showing the House Battery Bank info (charging voltage, current and status)

**CH2 / CH3** - When displayed in solid means the input power is getting from the related channel and the other channel will be flashing if it is available but not charging

**V** - The numerical value showing on the display is in voltage (V)

**A** - The numerical value showing on the display is in current (A)

**Auto** - 'Silent Mode' is activated. More details in 'Button Functions'

**Priority** - The CH3 Alternator/Start Battery terminal voltage is high or the unit is set to 'Manual Override Mode'. More details in 'Button Functions'



**Mode** - Charging mode setting (only displayed during unit setting)

**Temp** - Temperature setting (only displayed during unit setting)

## Digital Display

- During the charging process, the display shows 'CH1' charging voltage, current, and status repeatedly, and 'CH2' or 'CH3' is solid to indicate the recent active input source. If the other input channel ('CH3' or 'CH2' respectively) is available and its voltage is above its corresponding 'Start-Up' voltage threshold, the icon will be flashing.
- When  'INFO' button is pressed once during the charging process, the display will change to show CH2 voltage for 3 seconds and CH3 voltage for 3 seconds. The display will then go back to normal mode automatically, and show the CH1 information again.
- When the House Battery Bank (CH1) is fully charged, the display shows 'CH1' together with a cyclic sequence of its voltage, current, and the icon 'FLO' (for Float) repeatedly on the display.
- The selected 'battery type' icon remains on most of the time when the display is ON (i.e. during the charging process, setting menu, etc.)
- The 'Priority' icon turns ON when the 'Control' terminal is connected to high or the unit is set to 'Manual Override' mode. For more details, read the following table.

## Button Functions

	<ul style="list-style-type: none"> <li>• During normal charging operation, press once to change the display to show CH2 and CH3 voltage and press once more to go back to normal display.</li> <li>• Anytime the display is on* by whatever reason (except during the setting menu), press and hold for more than 3 sec. to enter the unit Setup Mode. To leave the menu, do the same or wait for about 10-15 sec pushing no button at all.</li> <li>• When both CH2 and CH3 are not available (i.e. below their corresponding Start-Up voltage thresholds), the display will go OFF to save house battery. Pressing and holding this button for more than 3 seconds, will temporarily trigger the display showing the sequence of all the three channels voltages, all the icons, the software revision numbers, and finally the CH1 voltage and current alternately for a few seconds, before finally going off.</li> </ul>
	<ul style="list-style-type: none"> <li>• During the charger Setup Mode, this button is used to confirm (save) the setting, and continue to the next one. Note: The selected setting will quickly flash 3 times to acknowledge the setting.</li> <li>• <b>Manual Override Mode:</b> Anytime the display is on* by whatever reason (except during the setting menu) press and hold this button for more than 10 seconds to enable this mode. The "Priority" icon will be displayed. In this mode, the voltage thresholds to start and use of CH3 as the charging source, are reduced so to enforce its use even more. Use the same procedure to turn off the 'Manual Override Mode' when it is not required. This mode is disabled after either turning the unit off or disconnecting the house battery.</li> <li>• Please note: If 'Manual Override Mode' is used and left on, there is a risk of flattening the start (vehicle) battery (CH3). The preferred method is to use the automatic override mode by connecting the ignition "+" signal (or even better a "+" one indicating engine running) to the "Control" terminal of the charger, so to make sure that the Override Mode is activated only when the engine alternator is running. This automatic setting is useful for vehicles equipped with Smart Regenerative Alternators (SRCS) which supply maximum voltages as low as 12.4V</li> <li>• <b>Equalization Mode:</b> With "Flooded" battery type setting, anytime the display is on* by whatever reason (except during the setting menu), press and hold the "NEXT" and "SET" buttons together for more than 5 sec. to enable the equalization mode in the CH1 (House Battery). The display will temporarily show "Eq" and the "Flooded" icon.</li> <li>• Please note: the battery has to be set to "Flooded" type in order to have this function enabled.</li> </ul>
	<ul style="list-style-type: none"> <li>• During the charger Setup Mode, this button is used to change to the next setting of a specific parameter.</li> <li>• <b>'Silent' (Fan OFF) mode:</b> Anytime that the display is on* by whatever reason (except during the setting menu), press and hold this button for more than 3 seconds to force the fan to turn OFF. The "Auto" icon will turn ON. The charger current will reduce to about half the set current. Use the same procedure to disable the 'Silent Mode' and turning the "Auto" icon Off. This functionality will be done automatically after 12 hours.</li> </ul>
<p><b>Note</b> * If the display is off (i.e. when in battery-save condition with both CH2 and CH3 not available) you can turn it on by using the "INFO" button as explained above, and waiting for the <u>complete</u> sequence until showing the CH1 voltage and current. Then, push and hold the corresponding button or buttons to enable the desired operating mode ("Setup", "Manual Override", "Equalization", or "Silent")</p> <p><b>General Note:</b> Every time the "INFO", "NEXT" and/or "SET" buttons are pressed, the back light will illuminate and automatically turn off after 60 seconds. When the display is in a temporary showing condition (i.e. during the setting menu, or after the "INFO" button sequence explained above), it will enter the power-save mode and go off if no push button is pressed for approximately 10-15 sec.</p>	

## Automatic Override Functions

When a positive signal is applied to the "Control", the Override (Priority) mode is enabled, allowing the connection to the CH3 (vehicle battery) at a lower Start-Up voltage threshold >12.3V/24.6V (from the normal >13.2V/26.4V) on a 12V/24V nominal start battery input respectively.

## Custom Setting Your Charger

Use the "INFO", "SET", and "NEXT" pushbuttons to enter the setup mode and its setting menu, select the setting of a specific parameter, and save & advance to the next parameter, respectively. Refer to the detailed explanation in the table above.

## Understanding the Three-Stage (Mode 3), Two-Stage (Mode 2) Charging

The Three-Stage Charging (Mode 3) consists of Bulk, Absorption and then Float stages. During the Bulk stage, the house battery (on CH 1) accepts the maximum constant current from the charger as per the setting. In the Absorption stage, the battery voltage is held to constant voltage and the charging current will slowly reduce. In Float stage, the charger continuously produces lower

constant float voltage to fully top up and maintain the battery in a fully charged state. The charger will automatically restart the full charging cycle if it senses the battery bank is discharged to lower than 12.5V for lead acid batteries and 13.3V for lithium batteries.

Similar to Three-Stage Charging, the Two-Stage Charging (Mode 2) has only Bulk and Absorption charging stage. Charger will terminate battery charging once it reaches the Absorption to Float (“L”) current setting. The charger will automatically restart the full charging cycle if it senses the battery bank is discharged to lower than 12.5V for lead acid batteries and 13.3V for lithium batteries.

### Manual Battery Temperature Compensation Setting

There are three manual battery temperature settings on the unit (‘Lo’, ‘nor’ and ‘hi’). Select the proper setting based on the room temperature as per the following table. The unit is able to make a more accurate and automatic temperature compensation when the optional BTS is connected to it. See more details in the next section. If using Lithium batteries, always set the manual room temperature to “nor” (Normal).

Temperature Setting	Existing Battery Room Temperature	Battery Type	Voltage adjustment from 25°C normal setting
Low (Lo)	< 5°C	GEL, Flooded	+0.675V
		AGM	+0.525V
Normal (nor)	> 5°C and < 30°C	GEL, Flooded, AGM (always for Lithium)	0V
			0V
High (hi)	< 30°C	GEL, Flooded	-0.270V
		AGM	-0.210V

### Automatic Battery Temperature Compensation using the BTS

The Battery Temperature Sensor (BTS) is an optional accessory for the charger to protect your battery and provide better charging voltage accuracy, by making small adjustments to it, based on the temperature measured directly on the battery. No special setting is required. The unit automatically detects when the sensor is plugged into its corresponding “BTS” jack port located in the DC wiring compartment, and overrides the manual temperature setting (i.e. “Lo”, “Nor”, and “Hi”). It is highly recommended to be installed on the main battery bank negative terminal.

With this optional feature, the charging voltage is automatically adjusted as per the following table.

Measured Battery Temperature	Automatic Battery Charging Voltage Adjustment from 25°C	
	Flooded and GEL type	AGM type
< 25°C	+0.027V / °C	+0.021V / °C
25°C	0V	0V
> 25°C	-0.027V / °C	-0.021V / °C

Additionally, the BTS allows the triggering of the E07 and A02 messages corresponding to the battery over-temperature shutdown and alarm, respectively.

The BTS is not intended for Lithium batteries. If using Lithium batteries, always set the manual room temperature to “nor” (Normal), and leave the BTS disconnected from the unit.

### Procedure to Set or View Charger Setting

Follow the procedure or sequence in Appendix A1 and A2 (see back of this manual) to set or view the charger setting.

### Procedure to Equalize Flooded Battery

**DANGER:** Explosion Hazard. The battery generates explosive gases during equalization. Follow all the battery safety precautions listed in the manual.

**DANGER:** Explosion Hazard and Risk of Battery damage. When using the equalization mode, the user has to be sure the battery connected to the channel is a flooded battery type. Equalizing a non-flooded battery may overcharge the battery and may cause the battery to explode.

**CAUTION:** Risk of Battery and Equipment damage. Only Flooded lead-acid batteries can be equalized. Consult your battery manufacturer or read the battery manual when you try to equalize your batteries. Disconnect any DC load connected to the battery, as during equalize mode, the charger will produce 15.5V on 12V model, or 31.0V on 24V model, to the batteries. You must monitor the battery-specific gravity throughout the equalization process to determine the end of the equalizing cycle.

**Note:** The equalization function although included in the unit will rarely be used. To activate, the battery bank must be in float stage, and stage activation is performed manually. A typical vehicle will not be long enough for the unit function to complete the process. The MPPT Solar function may provide enough time for Equalization, but the best recommendation will be using an AC powered battery charger. KISAE does manufacture a line of smart AC battery chargers, please consult [www.kisaepower.com](http://www.kisaepower.com).

Before setting the equalization mode, please be sure the battery is a flooded battery type. When

the battery equalization is enabled, the charger will automatically fully charge the battery bank and will then follow with 1 hour of equalization. Check the battery electrolyte level during the equalization period. If necessary, refill with distilled water only. All cells should have similar electrolyte levels. If distilled water is added, batteries must undergo a complete charge cycle. The charger cannot determine when to terminate the equalization of the battery, a one hour time-out is set and this is used as a safety feature to require the user to continually re-activate it as necessary after checking batteries manually. Use the following procedure to setup the charger for battery equalization. With "Flooded" setting, press and hold both the "NEXT" and "SET" pushbuttons together for more than 5 seconds to force the charger to go into Equalize mode and it will start equalizing the flooded battery. Please note the battery mode setting has to be set to 'Flooded' battery type in order to have this function activated.

### Understanding the Protection Features

**De-rating Charging Current:** When the charger's internal temperature is above 60°C, the maximum charger current will de-rate to 1/2 of the value, and the A01 warning code is displayed. The charger will recover automatically back to maximum charging current when its internal temperature drops to below 58°C.

**Over Temperature Shutdown:** When the charger's internal temperature is above 65°C, the charger will shut down and E06 error code is displayed. It will recover automatically when its internal temperature drops to below 40°C.

**Minimum House Battery Operating Voltage (Unit Start Up Voltage):** The charger is designed to charge house battery bank batteries with terminal voltage greater than 8.0Vdc on DMT1230, 1250 and 16V on DMT2430.

**Note** \*: In the case of having the unit inoperative because the CH1 house battery voltage is lower than the minimum operating voltage of 8V / 16V, you do not necessarily need to use an external battery charger to recover it. Try to use the following procedure to boost the house battery bank to above the minimum house battery operating voltage:

- 1) For DMT1230, 1250 using CH 2 (Solar Array/Panel): Turn unit off. Use a proper jumper to temporary connected CH2 "+" to Ch 1 "+". Remove the jumper when CH 1 is above the unit start up voltage (8Vdc) and restart the unit.
- 2) For DMT2430 using CH2 (24V Solar Array/Panel): Turn unit off. Use a proper jumper to temporary connected CH2 "+" to Ch 1 "+". Remove the jumper when CH 1 is above the unit start up voltage (16Vdc) and restart the unit.

**CAUTION:** Please notice that using a jumper to connect the positive terminal of CH 1 and CH 2 will stop the control and regulation functions of the house battery. Therefore, keep this temporary bypass to increase the CH1 house battery voltage just enough to allow the unit to operate. Then, disconnect the bypass and let the unit work as normal.

### Understanding the Display Code

Codes will show on the display when either a function or internal warning / fault, such as high internal temperature or DC out-of-range is detected and the charger may shut down to protect itself until the fault has cleared. See table description below for more information.

Code	Description
bUL	<b>The charger is in Bulk Charging Stage</b> <b>Bulk or Boost charge:</b> The battery is charged at full rated output current of the charger until the battery reaches its final charging voltage, known as its absorption voltage. In this step, approximately 80% of the battery is recovered as fast as possible.
Abs	<b>The Charger is in Absorption Charging Stage</b> <b>Absorption charge:</b> With the charger voltage held steady, the remaining 20% is replaced with the charger allowing the current to taper off as the battery approaches full charge.
FUL	<b>The Charger is in Float Charging Stage &amp; Power Supply Mode</b> <b>Float Charge:</b> Finally, in the float stage the charger voltage is lowered and held at a constant and safe predetermined level. This prevents the battery from being overcharged, yet allows the charger to supply enough current to make up for the self-discharge losses of the battery, while supporting any additional loads connected to the battery (such as DC lighting and refrigerators). This stage allows for the charger to be used as a DC power supply.
CHE	<b>CH3 Input Voltage Check</b> This is displayed for 5 sec. every 3 minutes when charging from the CH3 Start-Battery/Alternator input. During this 5 sec. checking period, the CH3 is internally disconnected to check its voltage and to decide if it meets the corresponding Under-Voltage-Recovery-Voltage (there are two possible ones), so to continue charging or not. See Section 6 for more details.
E01	<b>CH3 High Input Voltage Shutdown</b> This means the unit has detected that the CH3 Start/Alternator input has gone above 16.0V on a 12V input battery or 32.0V on a 24V input battery. This error will clear once the input has dropped below 15.5V on a 12V battery input or 31.0V on a 24V battery input.
E02	<b>CH3 Low Input Voltage Shutdown</b> This means the unit has detected that the input from the CH3 Start/Alternator has gone below 10.5V on a 12V battery input or 21.0V on a 24V battery input. This error will clear once the input has risen above the Start-Up voltage threshold of 13.2V/12.3V on 12V CH3 battery system, or >26.4/24.6V on 24V CH3 battery system, under Normal/Priority mode respectively.



	<p><b>If you have this error:</b></p> <ul style="list-style-type: none"> <li>• Confirm the voltage of your CH3 Start Battery is above the corresponding Start-Up voltage above</li> <li>• Check you have not left the "Priority" (Override) feature activated (Manual or Auto), when having no engine and so its alternator not running.</li> <li>• Check the battery cable from the Start Battery is properly sized, to avoid excessive voltage drop.</li> <li>• Make sure there is not any loose terminal or blown fuse.</li> <li>• Check if there are DC loads drawing current from the CH3 Start battery, resulting in a net discharging current.</li> </ul>
E03	<p><b>CH2 High Input Voltage Shutdown</b></p> <p>This means the input from the CH2 Solar input has gone above 50V. This error will clear once the input drops below 48.0V.</p> <p><b>If you have this error:</b></p> <ul style="list-style-type: none"> <li>• Check the specification of your panels – the Volts Open Circuit (VOC) should not exceed 50Voc.</li> <li>• If having panels in series for 24V nominal, make sure its voltage in open circuit (Voc) does not exceed the 50V when having maximum sunlight condition. Otherwise, consider connecting the solar panels in parallel (i.e. + to + and – to –) for a 12V nominal panel array.</li> </ul>
E04	<p><b>CH2 Low Input Voltage Shutdown</b></p> <p>The unit has detected the input from the Solar Array cannot sustain voltage above 14.5V.</p> <p><b>If you have this error: This is not necessarily a malfunction.</b></p> <ul style="list-style-type: none"> <li>• Check that you are not in a low light/non- direct sunlight situation i.e. early morning /late afternoon, or even at night.</li> <li>• This may also happen if your solar panels are inside of a shed with a skylight or outside under Flood Lights.</li> </ul> <p>If you find this is happening with your unit when stored, we recommend fitting a DC breaker to the output of the Charger and turning it off when the unit is not in use.</p>
E05	<p><b>CH1 High Input Voltage Shutdown</b></p> <p>This means the unit has detected that the CH1 Main/House battery has gone above 16.0V/32V on DMT1230-DMT1250 / DMT2430 respectively. This error will clear once the input has dropped below 15.5V/31V respectively.</p> <p>This may be due to charging from another charging source (i.e. Another solar controller or AC battery charger) with either an excessively higher voltage regulation setting or a malfunction.</p>
E06	<p><b>Over Temperature Shutdown</b></p> <p>When the charger's internal temperature rises above 65°C, the charger will shutdown. It will recover automatically when the environmental temperature drops below 40°C.</p> <ul style="list-style-type: none"> <li>• Check to make sure the fan is working.</li> <li>• Make sure the unit has good ventilation.</li> </ul>
E07	<p><b>BTS Over Temperature Shutdown</b></p> <p>This means the Battery Temp Sensor has detected that the batteries are too hot &gt; 60°C and have shut down to not over charge the batteries. The unit will return back to normal charging once the battery temperature sensor is &lt; 56°C.</p> <p><b>If this occurs, check the temperature of the batteries.</b></p> <ul style="list-style-type: none"> <li>• If the Batteries are Hot – you may have a dropped cell or faulty battery. Stop all charging and see your local battery shop to get your batteries tested.</li> <li>• Check the batteries and the charging current. The charging current may be set too high.</li> <li>• If the Batteries/Terminals are still cool or only warm, you may have a bad temp sensor. Unplug the temp sensor and contact KISAE.</li> </ul>
A01	<p><b>Over Temperature Warning</b></p> <p>When the charger's internal temperature is &gt; 60°C, the unit will show 'A01'. If the ventilation of the unit is not improved, it will lead to 'E06'- <b>Unit Over Temperature Shutdown</b>.</p> <p>The 'A01' warning code will disappear when the internal temperature drops to &lt; 58°C.</p> <ul style="list-style-type: none"> <li>• Check if there is an object has blocked the air ventilation of the unit.</li> <li>• Check if the fan is working.</li> <li>• Make sure the unit has good ventilation.</li> </ul>
A02	<p><b>BTS High Temperature Warning</b></p> <p>When the battery temperature sensor is &gt; 58°C, the display will show 'A02'. If the ventilation of the battery environment is not improved and the temperature continuously rises, it will lead to 'E07'- <b>BTS Over Temperature Shutdown</b>.</p> <p>The 'A02' warning code will disappear when the measured temperature drops to &lt; 56°C.</p> <ul style="list-style-type: none"> <li>• Check the batteries and the charging current. The charging current may be set too high.</li> <li>• Make sure the batteries have good ventilation.</li> </ul>

## 7. SPECIFICATIONS

Note: Specifications are subject to change without notices.

<b>Output Rating</b>			
Output Current (Maximum)	30A		30A
Output Voltage	12V Nominal		24V Nominal
Output Power (Maximum)	465W	775W	930W
<b>Charger DC Output- House Battery (CH1):</b>			
Selectable Battery Type	GEL, AGM, Flooded, Lithium, Program		
Bulk /Float Voltage Range	GEL:	14.4 / 13.7 Vdc	28.8 / 27.4 Vdc
	AGM:	14.6 / 13.6 Vdc	29.2 / 27.2 Vdc
	Flooded:	14.4 / 13.3 Vdc	28.8 / 26.6 Vdc
	Lithium:	13.9 - 14.6 Vdc	27.8 – 29.2 Vdc
	Program:	13.8 - 14.8 Vdc	27.6 – 29.6 Vdc
Restart Voltage (GEL, AGM, Flooded, Program)	12.5 Vdc		25.0 Vdc
Restart Voltage (Lithium)	13.3 Vdc		26.6 Vdc
Charger Current (User Selectable)	5/ 10 / 20 / 30A	5-50A (5A steps)	5/ 10 / 20 / 30A
Equalized Voltage (Flooded Battery only)	15.5 Vdc		31.0 Vdc
Equalized Charging Current	10% of Bulk Current Setting		
Charging Control	GEL, AGM Flooded, Program Mode: Two or Three Stages Lithium: Three Stages only		
DC Output Bank	Single		
Current draw from CH1 with unit ON	< 70 mA		
Current draw from CH1 with Unit OFF	< 200 uA		
Battery Temperature Setting	Low / Normal / High (automatically overridden with optional BTS)		
Efficiency	95%		
Minimum Operating Voltage	8.0 Vdc		16.0 Vdc
<b>DC Input - Solar Array/Panels (CH2- Solar):</b>			
Input Voltage	14.5 – 50 Vdc		
Maximum Solar Input Current	30A		
Maximum Solar Input Power: 12V Panel	500W (600W max)	500W (600W max)	500W (600W max)
24V Panel	500W (600W max)	750W (800W max)	900W (1080W max)
<b>DC Input – Alternator/ Start Battery (CH3- Alternator/Start):</b>			
Input Voltage	10.5 – 16.0 Vdc / 21 – 32 Vdc		
Maximum Input Current (as per max. setting)	50A		
<b>Environmental and Operating Temperature:</b>			
Storage Range	-40° to 70° C (-40° to 158° F)		
Operating Range	-20° to 60° C (-4° to 140° F)		
Humidity	5-95%, RH non-condensing		
Ingress Protection	IP32		
<b>Weight and Dimensions:</b>			
DMT1230, 1250	4.1 lb., 9.5x6.8x2.9 inches (1.85 Kg, 242x172x74 mm)		
<b>Regulatory Compliance:</b>			
Standards/EMC (North America)	Class B according to FCC part15B and ANSI C63.4		
Standards/EMC (European Union)	CE marked for the EMC directive 2004-108-EC Complying with EN55014-1, EN55014-2, EN61000-3-2 and EN61000-3-3 (as equivalent IEC standards series)		

### Optional Accessories:

Remote Digital Display

DMTRM01 (For DMT1250, DMT2430 use only)

Battery Temperature Sensor

BTS-10K (Not required for Lithium or Program settings)



## 8. WARRANTY

### One Year Limited Warranty

The limited warranty program is the only one that applies to this unit, and it sets forth all the responsibilities of **KISAE**. There is no other warranty, other than those described herein. Any implied warranty of merchantability of fitness for a particular purpose on this unit is limited in duration to the duration of this warranty.

This unit is warranted, to the original purchaser only, to be free of defects in materials and workmanship for one year from the date of purchase without additional charge. The warranty does not extend to subsequent purchasers or users.

Manufacturer will not be responsible for any amount of damage in excess of the retail purchase price of the unit under any circumstances. Incidental and consequential damages are specifically excluded from coverage under this warranty.

This unit is not intended for commercial use. This warranty does not apply to damage to units from misuse or incorrect installation/connection. Misuse includes wiring or connecting to improper polarity power sources.

### RETURN/REPAIR POLICY:

If you are experiencing any problems with your unit, please contact our customer service department at [info@kisaetechnology.com](mailto:info@kisaetechnology.com) or phone 1 877 897-5778 before returning product to retail store. After speaking to a customer service representative, if products are deemed non-working or malfunctioning, the product may be returned to the purchasing store within 30 days of original purchase. Any defective unit that is returned to manufacturer within 30 days of the date of purchase will be replaced free of charge.

If such a unit is returned more than 30 days but less than one year from the purchase date, manufacturer will repair the unit or, at its option, replace it, free of charge. If the unit is repaired, new or reconditioned replacement parts may be used, at manufacturer's option. A unit may be replaced with a new or reconditioned unit of the same or comparable design. The repaired or replaced unit will then be warranted under these terms for the remainder of the warranty period. The customer is responsible for the shipping charges on all returned items.

### LIMITATIONS:

This warranty does not cover accessories, such as adapters and batteries, damage or defects result from normal wear and tear (including chips, scratches, abrasions, discoloration or fading due to usage or exposure to sunlight), accidents, damage during shipping to our service facility, alterations, unauthorized use or repair, neglect, misuse, abuse, failure to follow instructions for care and maintenance, fire and flood.

If your problem is not covered by his warranty, contact our Customer Service Department at [info@kisaetechnology.com](mailto:info@kisaetechnology.com) or 1 877 897-5778 for general information if applicable.

**Service Contact Information**  
Email:[info@kisaetechnology.com](mailto:info@kisaetechnology.com)  
Phone: 1-877-897-5778  
[www.kisaepower.com](http://www.kisaepower.com)

**KISAE**<sup>SM</sup>

# Appendix A1 LEAD ACID Mode

REV 2.0

To enter the **Charger Function Menu**, Press and hold 'INFO' button for 3 seconds when the unit is running at normal operation with display showing CH1 information  
 After entering the **Charger Function Menu**, display will show the existing battery type

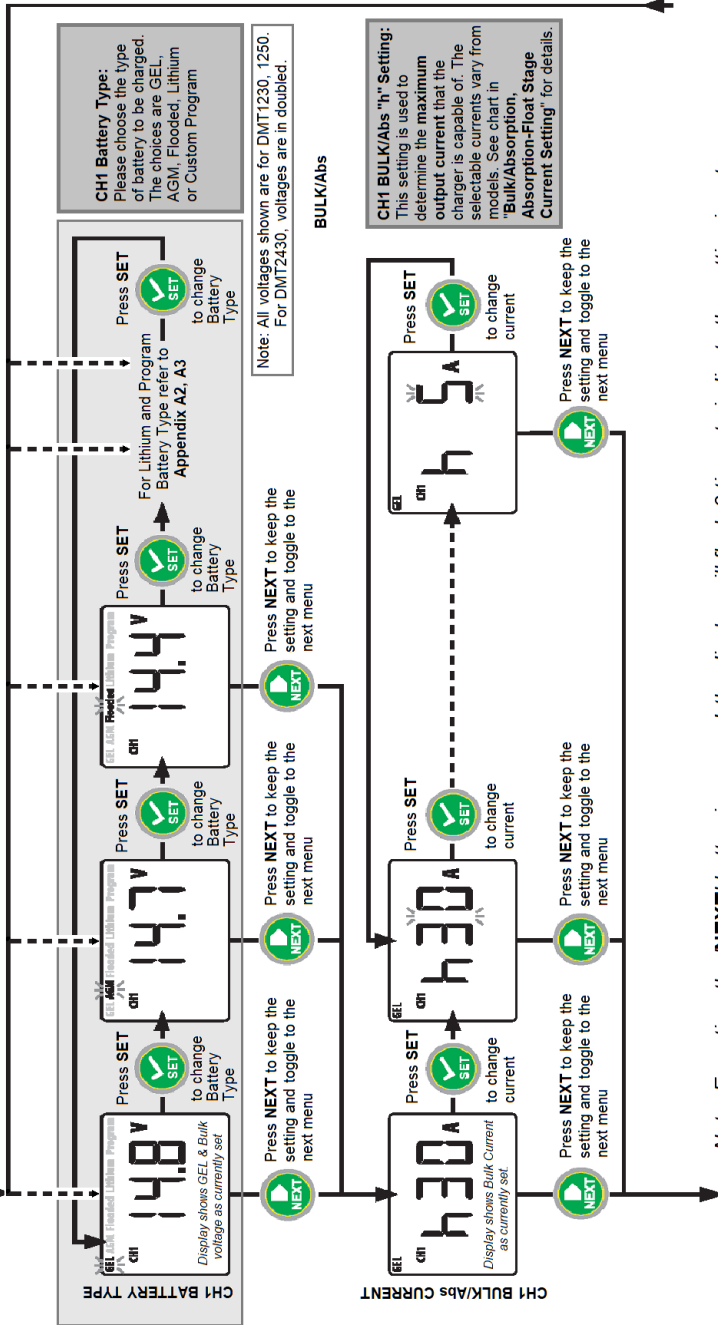

Note: Everytime the 'NEXT' button is pressed, the display will flash 3 times to indicate the setting is set. The unit setting will automatically terminate if none of the three push buttons are triggered for more than 10 seconds.

# Appendix A1 continued

REV 2.0

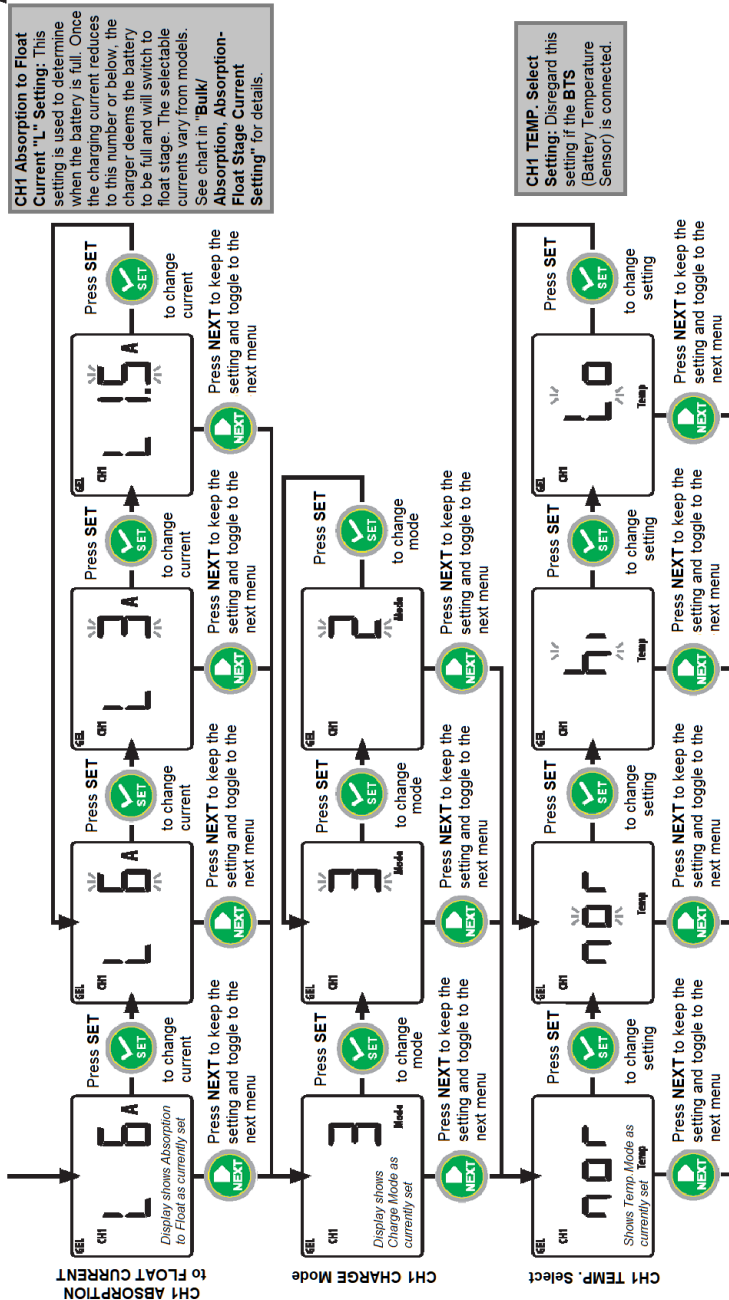

Go back to the related battery type in Appendix A1 CH1 Battery Type setting

## WARNING: FIRE HAZARD

When choosing the battery type, voltage and current setting, please consult the battery manufacturer for all the values. Using the wrong setting to charge the battery may overcharge, damage the battery and may cause a fire.

# Appendix A2 LITHIUM Mode

REV 2.0

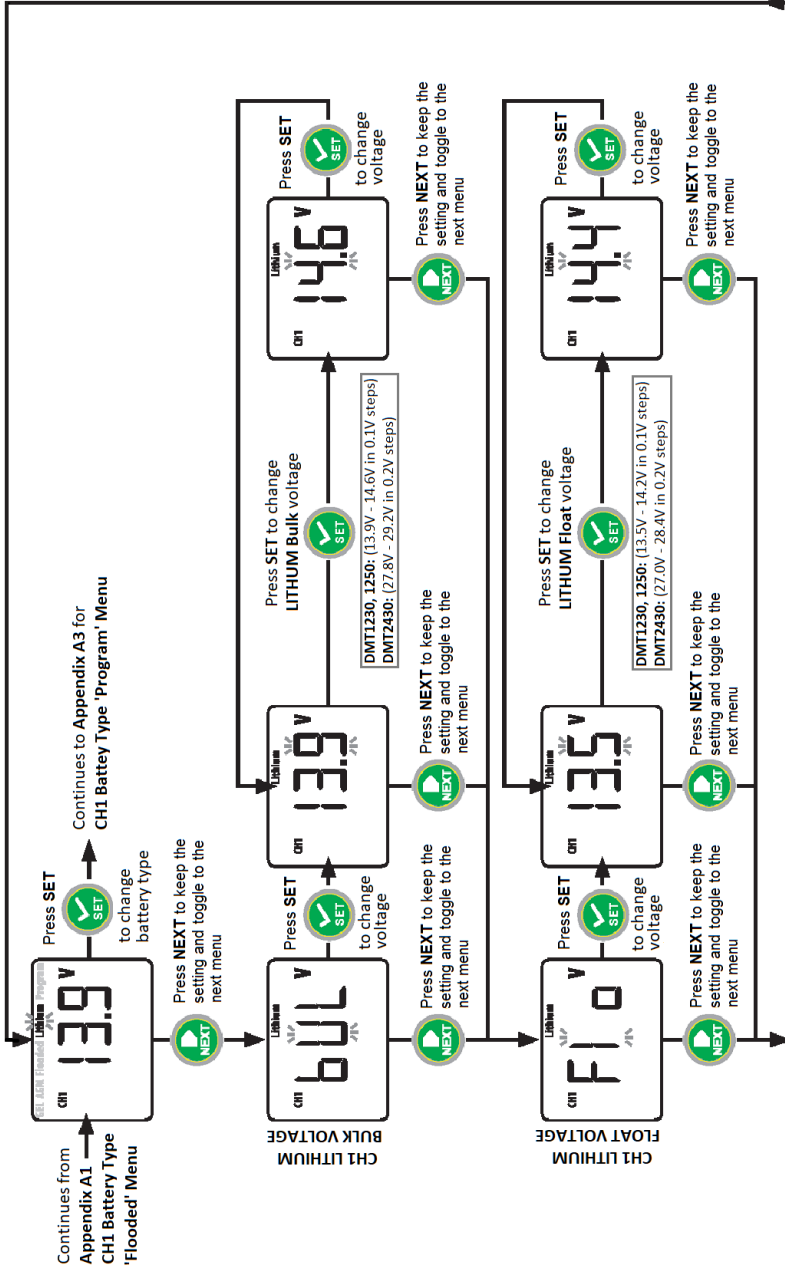

## WARNING: FIRE HAZARD

When choosing the battery type, voltage and current setting, please consult the battery manufacturer for all the values. Using the wrong setting to charge the battery may overcharge, damage the battery and may cause a fire.

# Appendix A2 continued

REV 2.0

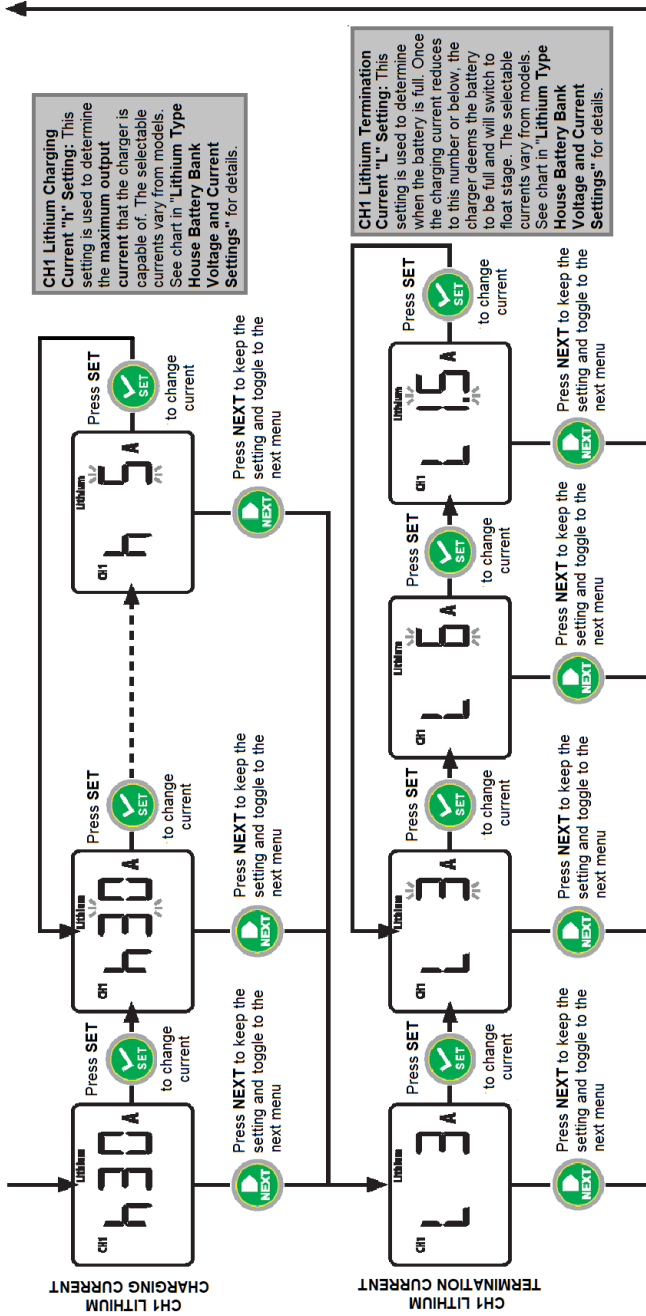

## WARNING: FIRE HAZARD

When choosing the battery type, voltage and current setting, please consult the battery manufacturer for all the values. Using the wrong setting to charge the battery may overcharge, damage the battery and may cause a fire.

# Appendix A3 PROGRAM Mode

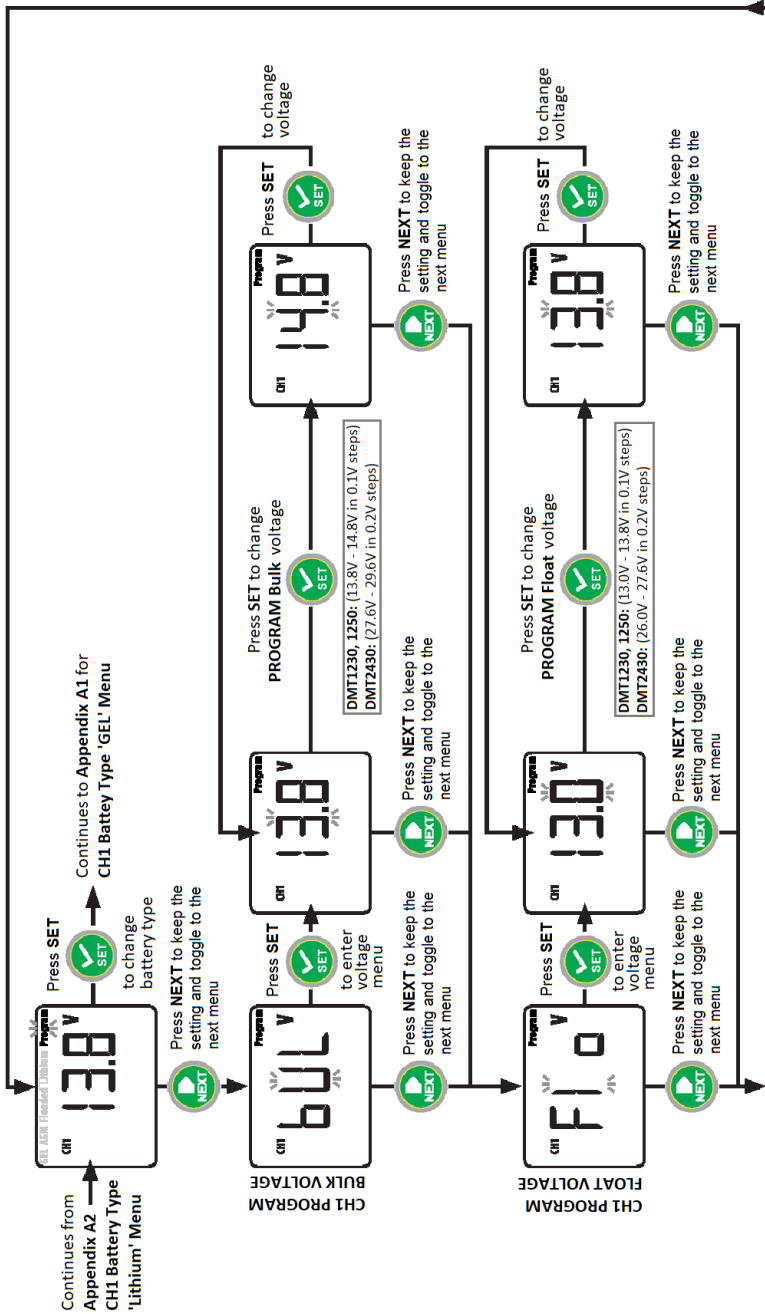

## WARNING: FIRE HAZARD

When choosing the battery type, voltage and current setting, please consult the battery manufacturer for all the values. Using the wrong setting to charge the battery may overcharge, damage the battery and may cause a fire.

# Appendix A3 continued

REV 2.0

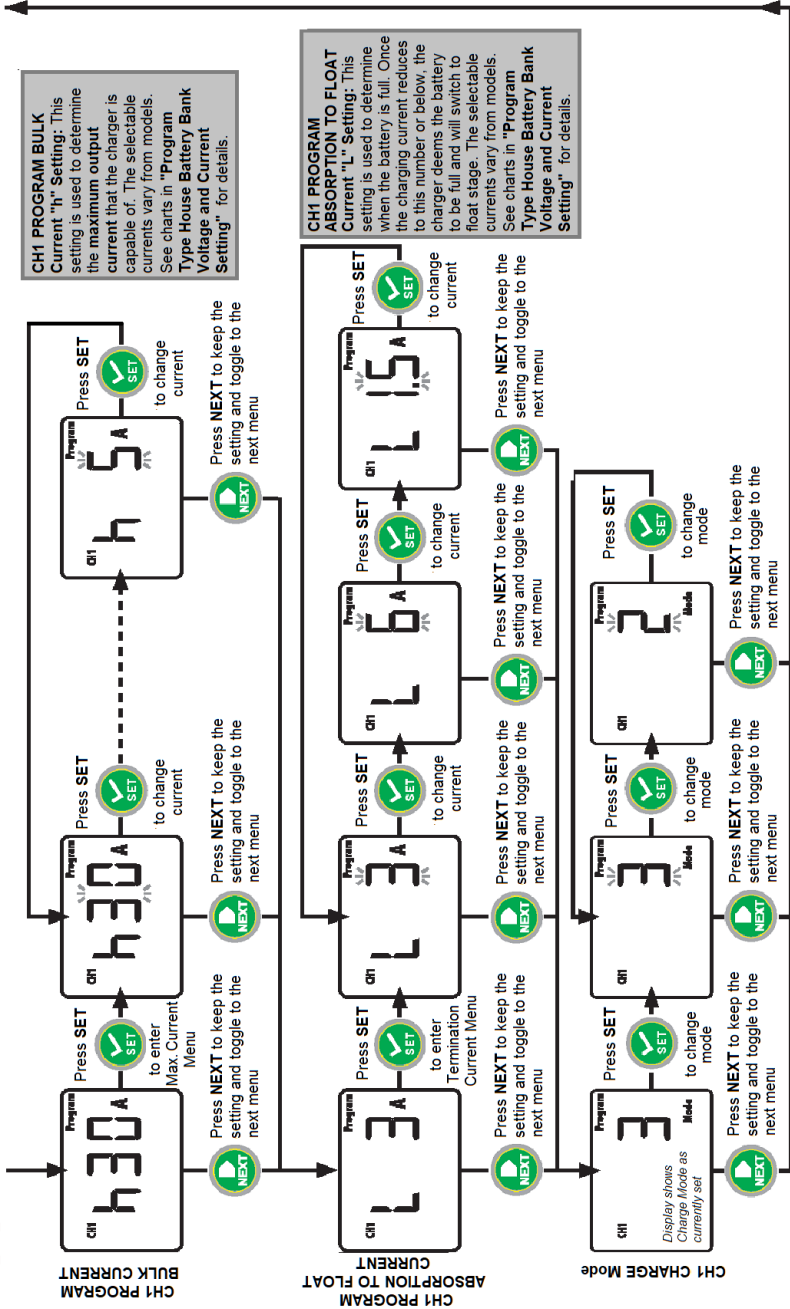

Go back to Appendix A3 CH1 Program Mode setting

## WARNING: FIRE HAZARD

When choosing the battery type, voltage and current setting, please consult the battery manufacturer for all the values. Using the wrong setting to charge the battery may overcharge, damage the battery and may cause a fire.

**KISAE<sup>SM</sup>**